

▼ STW Servo Controlled Electric Wrench



Maximum Torque: 100-15000N·m

Accuracy: ±2%

Maximum Working Pressure: 70MPa

- Covers a torque range of 100–15000 N·m, suitable for various complex working conditions.
- Supports wide voltage input of 100–253 V / 45–66 Hz, maintaining accurate and stable torque output throughout operation.
- Equipped with multi-stage adjustable torque and automatic stop function to ensure torque accuracy and operational repeatability.
- Combines the advantages of high accuracy, high repeatability and high speed, effectively improving bolting efficiency.
- Complies with IP54 standard, featuring dustproof, moisture-proof and rain-splash resistance, adapting to harsh working environments.
- Servo motor with high-precision sensor achieves ±3% torque accuracy and ±2% repeatability via closed-loop control.
- Intelligent display: shows real-time torque and angle data, supports angle control and counts nut rundown cycles.

▼ STW Technical Parameters

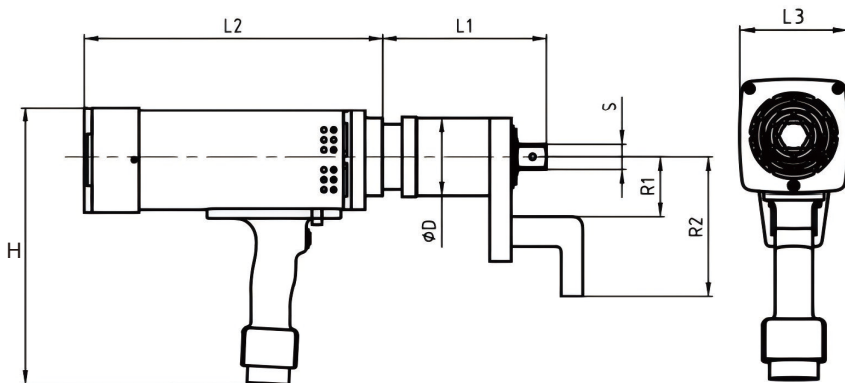

▼ STW Packing List

Item	Description	Qty
STW	Servo Precision Control Torque Wrench	1
Reaction Arm	-	1
Intelligent Control Box	-	1
Lifting Ring	-	2
Tool Case	-	1

Model	Min. Torque (N·m)	Max. Torque (N·m)	Drive	Dimensions (mm)							Max. Speed (RPM)	Weight (kg)
				D	L1	L2	L3	H	R1	R2		
STWC05	100	500	3/4"	65.3	105	307	99.5	279	40	100	45	5
STWC10	150	1000	3/4"	65.3	121.5	307	99.5	279	46	126	30	5.5
STWC15	250	1500	1"	80	168.5	307	99.5	279	60	140	19	6
STWC20	350	2000	1"	80	168.5	307	99.5	279	60	140	16	6
STWC30	400	3000	1"	88	181	307	99.5	279	60	150	10	7.5
STWC40	600	4000	1"	98	186	307	99.5	279	60	150	7	9
STWC60	1000	6000	1-1/2"	105	221	307	99.5	279	75	160	5	11.5
STWC80	2000	8000	1-1/2"	126	284	307	99.5	279	90	200	3.5	14
STWC100	2500	10000	1-1/2"	130	295	307	99.5	279	127	254	3	18
STWC150	4000	15000	1-1/2"	135	305	307	99.5	279	133	241	2.2	22

▼ STW Servo Electric Wrench Introduction



▼ STW Servo Electric Wrench with Touch Screen Control System

The touch screen control box allows operators to quickly set torque, configure forward or reverse rotation angles, adjust torque settings, download wrench operation efficiency data, and store all information. Data can be saved on the memory card inside the control box or downloaded to an external hard drive. An optional wireless Bluetooth data recording system enables users to store and transmit data remotely.



Intelligent Control Box - Main Interface

ABS wrench case as standard factory equipment