

## ▼ RR Double-Acting Hydraulic Cylinders



Rated Pressure: 70MPa

Rated Tonnage: 10-520ton

Stroke Range: 57-1219mm

- Outer ring threads, plunger threads and bottom mounting holes for easy installation (for most models)
- Paint-coated surface provides superior corrosion resistance
- Removable saddle protects plunger during operation
- Equipped the safety valve prevents accidental overload
- All cylinders are equipped with CEJN quick couplings and dust caps
- Wiper seals reduce contamination and extend service life of hydraulic cylinders
- Versatile design, reliable performance in harsh environments, ideal for long-cycle industrial use.

## ► RR Performance Introduction

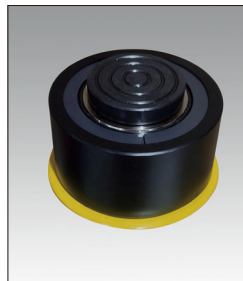
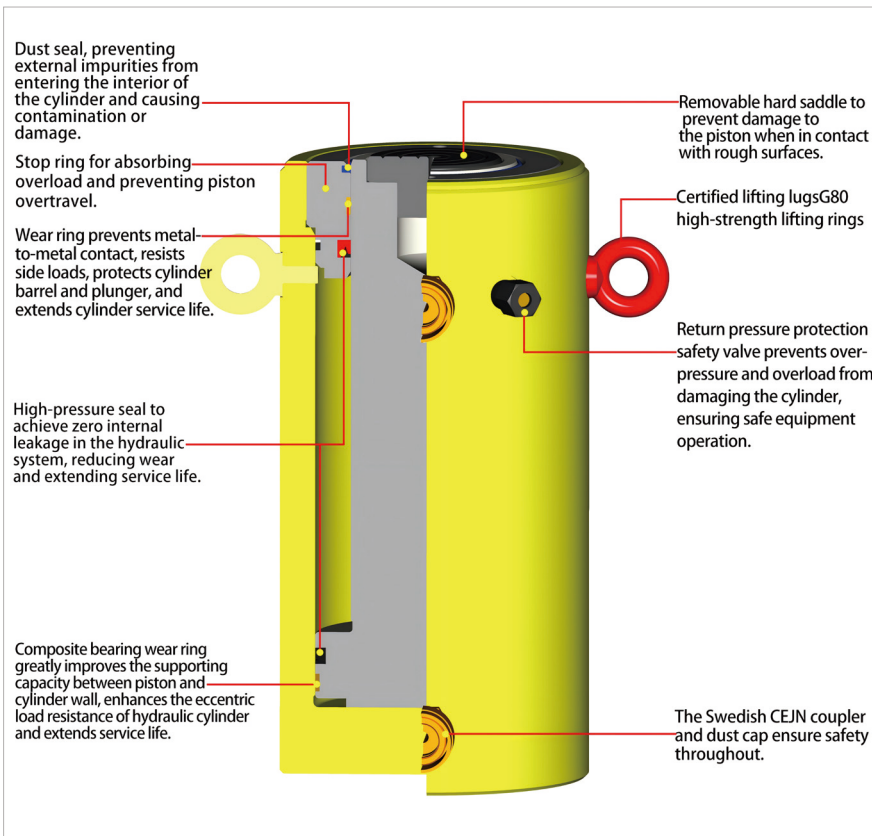

**Optional Recessed Saddle**  
RR series cylinders below 75 tons are equipped with plunger mounting holes for installing recessed saddles.



**Optimal Performance**  
Hydraulic pumps equipped with double-acting manual valves or solenoid valves deliver superior performance when used with RR series cylinders.

## Optional plug-in saddles for RR Series

Type	Applicable Cylinder	Saddle Model
Flat Type	RR10	A102F
Tilt Type	RR10	CATS12
Tilt Type	RR30	CATS52
Tilt Type	RR50	CATS100
Tilt Type	RR75	CATS100

## RR Series Standard Saddle

Saddle Type	Applicable Cylinder Model	Saddle Model
Groove Type	RR10	A102G
Groove Type	RR30	A252G

## ▼ Quick Selection Chart

Load Capacity (ton)	Stroke (mm)	Model	Max. Load Capacity (kN)		Effective Area (cm <sup>2</sup> )		Oil Volume (cm <sup>3</sup> )		Collapsed Height (mm)	Extended Height (mm)
			Extending	Retracting	Extending	Retracting	Extending	Retracting		
10	254	RR1010*	101	33	14.5	4.8	368	122	409	663
10	305	RR1012*	101	33	14.5	4.8	442	147	457	762
30	209	RR308*	295	53	42.1	19.1	879	400	394	603
30	368	RR3014*	295	53	42.1	19.1	1549	703	549	917
50	156	RR506	498	103	71.2	21.5	1111	335	331	487
50	334	RR5013	498	103	71.2	21.5	2378	718	509	843
50	511	RR5020	498	103	71.2	21.5	3638	1099	733	1244
75	156	RR756	718	156	102.6	31.4	1601	490	347	503
75	333	RR7513	718	156	102.6	31.4	3417	1046	525	858
95	168	RR1006	933	435	133.3	62.2	2238	1045	357	525
95	333	RR10013	933	435	133.3	62.2	4439	2071	524	857
95	460	RR10018	933	435	133.3	62.2	6132	2861	687	1147
140	57	RR1502	1386	668	198.1	95.4	1129	544	183	240
140	156	RR1506	1386	668	198.1	95.4	3090	1488	385	541
140	333	RR15013	1386	668	198.1	95.4	6597	3177	582	915
140	815	RR15032	1386	668	198.1	95.4	16145	7775	1116	1931
200	152	RR2006	1995	1017	285	145.3	4332	2209	430	582
200	330	RR20013	1995	1017	285	145.3	9405	4795	608	938
200	457	RR20018	1995	1017	285	145.3	13025	6640	765	1222
200	610	RR20024	1995	1017	285	145.3	17385	8863	917	1527
200	914	RR20036	1995	1017	285	145.3	26049	13280	1222	2136
200	1219	RR20048	1995	1017	285	145.3	34741	17712	1527	2746
325	153	RR3006	3201	1703	457.3	243.2	6997	3721	485	638
325	305	RR30012	3201	1703	457.3	243.2	13947	7418	638	943
325	457	RR30018	3201	1703	457.3	243.2	20889	11114	790	1247
325	609	RR30024	3201	1703	457.3	243.2	27850	14811	943	1552
325	915	RR30036	3201	1703	457.3	243.2	41843	22253	1247	2162
325	1219	RR30048	3201	1703	457.3	243.2	55745	29646	1552	2771
440	152	RR4006	4292	2297	613.1	328.1	9319	4987	538	690
440	305	RR40012	4292	2297	613.1	328.1	18700	10007	690	995
440	457	RR40018	4292	2297	613.1	328.1	28018	14995	843	1300
440	610	RR40024	4292	2297	613.1	328.1	37400	20014	995	1605
440	914	RR40036	4292	2297	613.1	328.1	56037	29988	1300	2214
440	1219	RR40048	4292	2297	613.1	328.1	74737	39996	1605	2824
520	153	RR5006	5108	2838	729.7	405.4	11164	6203	577	730
520	305	RR50012	5108	2838	729.7	405.4	22256	12365	730	1035
520	457	RR50018	5108	2838	729.7	405.4	33347	18526	882	1339
520	609	RR50024	5108	2838	729.7	405.4	44440	24689	1035	1644
520	915	RR50036	5108	2838	729.7	405.4	66768	36973	1339	2254
520	1219	RR50048	5108	2838	729.7	405.4	88951	49418	1644	2863

# Hydraulic Cylinders

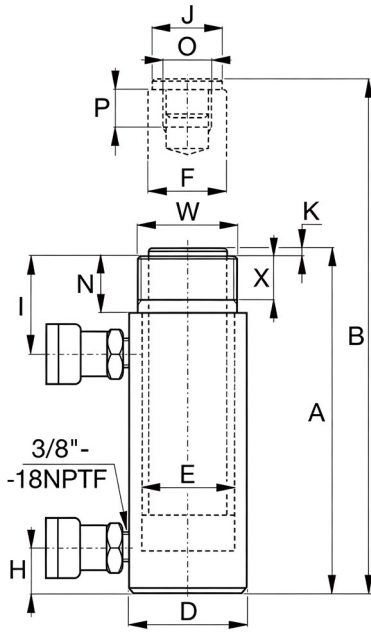

**RR1010 - RR3014**

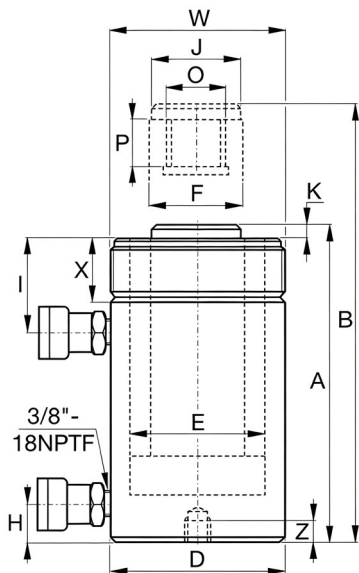

**RR506 - RR50048**

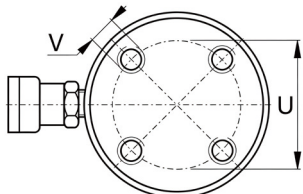

**RR1006 - RR30048**

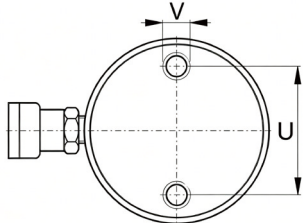

**RR4006 - RR50048**

RR506, RR5013, RR756, RR7513, RR1502, RR15032  
No mounting holes

- Outer ring threads, plunger threads and bottom mounting holes for easy installation (for most models)
- Paint-coated surface provides superior corrosion resistance
- Removable saddle protects plunger during operation
- Equipped the safety valve prevents accidental overload
- All cylinders are equipped with CEJN quick couplings and dust caps
- Wiper seals reduce contamination and extend service life of hydraulic cylinders
- Versatile design, reliable performance in harsh environments, ideal for long-cycle industrial use.

Load Capacity (ton)	Stroke (mm)	Model Number	Max. Load Capacity (kN)		Effective Area (cm <sup>2</sup> )		Oil Volume (cm <sup>3</sup> )		Collapsed Height A (mm)	Extended Height B (mm)	Outside Dia. D (mm)
			push	pull	push	pull	push	pull			
10	254	RR1010*	101	33	14.5	4.8	368	122	409	663	73
10	305	RR1012*	101	33	14.5	4.8	442	147	457	762	73
30	209	RR308*	295	53	42.1	19.1	879	400	394	603	101
30	368	RR3014*	295	53	42.1	19.1	1549	703	549	917	101
50	156	RR506	498	103	71.2	21.5	1111	335	331	487	127
50	334	RR5013	498	103	71.2	21.5	2378	718	509	843	127
50	511	RR5020	498	103	71.2	21.5	3638	1099	733	1244	127
75	156	RR756	718	156	102.6	31.4	1601	490	347	503	146
75	333	RR7513	718	156	102.6	31.4	3417	1046	525	858	146
95	168	RR1006	933	435	133.3	62.2	2238	1045	357	525	177
95	333	RR10013	933	435	133.3	62.2	4439	2071	524	857	177
95	460	RR10018	933	435	133.3	62.2	6132	2861	687	1147	177
140	57	RR1502	1386	668	198.1	95.4	1129	544	183	240	203
140	156	RR1506	1386	668	198.1	95.4	3090	1488	385	541	203
140	333	RR15013	1386	668	198.1	95.4	6597	3177	582	915	203
140	815	RR15032	1386	668	198.1	95.4	16145	7775	1116	1931	203
200	152	RR2006	1995	1017	285	145.3	4332	2209	430	582	247
200	330	RR20013	1995	1017	285	145.3	9405	4795	608	938	247
200	457	RR20018	1995	1017	285	145.3	13025	6640	765	1222	247
200	610	RR20024	1995	1017	285	145.3	17385	8863	917	1527	247
200	914	RR20036	1995	1017	285	145.3	26049	13280	1222	2136	247
200	1219	RR20048	1995	1017	285	145.3	34741	17712	1527	2746	247
325	153	RR3006	3201	1703	457.3	243.2	6997	3721	485	638	311
325	305	RR30012	3201	1703	457.3	243.2	13947	7418	638	943	311
325	457	RR30018	3201	1703	457.3	243.2	20889	11114	790	1247	311
325	609	RR30024	3201	1703	457.3	243.2	27850	14811	943	1552	311
325	915	RR30036	3201	1703	457.3	243.2	41843	22253	1247	2162	311
325	1219	RR30048	3201	1703	457.3	243.2	55745	29646	1552	2771	311
440	152	RR4006	4292	2297	613.1	328.1	9319	4987	538	690	358
440	305	RR40012	4292	2297	613.1	328.1	18700	10007	690	995	358
440	457	RR40018	4292	2297	613.1	328.1	28018	14995	843	1300	358
440	610	RR40024	4292	2297	613.1	328.1	37400	20014	995	1605	358
440	914	RR40036	4292	2297	613.1	328.1	56037	29988	1300	2214	358
440	1219	RR40048	4292	2297	613.1	328.1	74737	39996	1605	2824	358
520	153	RR5006	5108	2838	729.7	405.4	11164	6203	577	730	397
520	305	RR50012	5108	2838	729.7	405.4	22256	12365	730	1035	397
520	457	RR50018	5108	2838	729.7	405.4	33347	18526	882	1339	397
520	609	RR50024	5108	2838	729.7	405.4	44440	24689	1035	1644	397
520	915	RR50036	5108	2838	729.7	405.4	66768	36973	1339	2254	397
520	1219	RR50048	5108	2838	729.7	405.4	88951	49418	1644	2863	397

\*RR1010 and RR1012: N=32 mm; RR308 and RR3014: N=55 mm.

Rated Pressure: 70MPa

Rated Tonnage: 10-520ton

Stroke Range: 57-1219mm

RR Series  
Double-Acting  
Hydraulic  
Cylinder



Cyl. Bore Dia. (mm)	Plgr. Dia. F (mm)	Base to Adv. Port H (mm)	Base to Ret. Port I (mm)	Top to Ret. Port J (mm)	Saddle Dia. K (mm)	Plunger Internal Thread O	Plunger Thread Length P (mm)	Base Mounting Holes			Collar Thread W	Collar Thread Length X (mm)	Weight (kg)	Model Number
								Base Mounting Holes Bolt Circle U (mm)	Thread V	Thread Depth Z (mm)				
42.9	34.9	36	57	35	6	1"- 8	25	-	-	-	2¼"- 14	26	12	RR1010*
42.9	34.9	36	57	35	6	1"- 8	25	-	-	-	2¼"- 14	26	14	RR1012*
73.2	54.1	39	81	50	10	1½"- 16	25	-	-	-	3 <sup>5</sup> / <sub>16</sub> "- 12	49	18	RR308*
73.2	54.1	39	81	50	10	1½"- 16	25	-	-	-	3 <sup>5</sup> / <sub>16</sub> "- 12	49	29	RR3014*
95.2	79.5	28	76	71	2	1"- 12	25	-	-	-	5"- 12	44	30	RR506
95.2	79.5	28	76	71	2	1"- 12	25	-	-	-	5"- 12	44	52	RR5013
95.2	79.5	57	76	71	2	1"- 12	25	76	½"- 13	25	5"- 12	44	68	RR5020
114.3	95.2	30	81	71	6	1"- 12	28	-	-	-	5 ¾"- 12	50	41	RR756
114.3	95.2	30	81	71	6	1"- 12	28	-	-	-	5 ¾"- 12	50	61	RR7513
130.3	95.2	38	71	76	3	1¾"- 12	35	139	¾"- 10	25	6 <sup>7</sup> / <sub>8</sub> "- 12	50	61	RR1006
130.3	95.2	38	71	76	3	1¾"- 12	35	139	¾"- 10	25	6 <sup>7</sup> / <sub>8</sub> "- 12	50	93	RR10013
130.3	95.2	41	92	76	3	1¾"- 12	35	139	¾"- 10	25	6 <sup>7</sup> / <sub>8</sub> "- 12	50	117	RR10018
158.8	114.3	22	66	95	19	-	-	-	-	-	-	-	49	RR1502
158.8	114.3	49	84	114	19	3 <sup>3</sup> / <sub>8</sub> "- 16	35	158	¾"- 16	28	8"- 12	55	93	RR1506
158.8	114.3	49	84	114	19	3 <sup>3</sup> / <sub>8</sub> "- 16	35	158	¾"- 16	28	8"- 12	55	124	RR15013
158.8	114.3	76	88	114	19	3 <sup>3</sup> / <sub>8</sub> "- 16	35	158	¾"- 16	28	8"- 12	55	238	RR15032
190.5	133.4	57	96	133	22	-	-	127	1"- 8	25	-	-	147	RR2006
190.5	133.4	57	96	133	22	2½"- 12	63	127	1"- 8	25	9¾"- 12	54	199	RR20013
190.5	133.4	85	101	133	22	2½"- 12	63	127	1"- 8	25	9¾"- 12	54	204	RR20018
190.5	133.4	85	101	133	22	2½"- 12	63	127	1"- 8	25	9¾"- 12	54	279	RR20024
190.5	133.4	85	101	133	22	2½"- 12	63	127	1"- 8	25	9¾"- 12	54	383	RR20036
190.5	133.4	85	101	133	22	2½"- 12	63	127	1"- 8	25	9¾"- 12	54	483	RR20048
241.3	165.1	88	114	165	28	2½"- 12	82	158	1¼"- 7	44	12¼"- 12	58	200	RR3006
241.3	165.1	88	114	165	28	2½"- 12	82	158	1¼"- 7	44	12¼"- 12	58	312	RR30012
241.3	165.1	88	114	165	28	2½"- 12	82	158	1¼"- 7	44	12¼"- 12	58	385	RR30018
241.3	165.1	88	114	165	28	2½"- 12	82	158	1¼"- 7	44	12¼"- 12	58	469	RR30024
241.3	165.1	88	114	165	28	2½"- 12	82	158	1¼"- 7	44	12¼"- 12	58	628	RR30036
241.3	165.1	88	114	165	28	2½"- 12	82	158	1¼"- 7	44	12¼"- 12	58	780	RR30048
279.4	190.5	108	133	190	28	3"- 12	95	203	1½"- 6	50	14 <sup>1</sup> / <sub>8</sub> "- 8	65	303	RR4006
279.4	190.5	108	133	190	28	3"- 12	95	203	1½"- 6	50	14 <sup>1</sup> / <sub>8</sub> "- 8	65	399	RR40012
279.4	190.5	108	133	190	28	3"- 12	95	203	1½"- 6	50	14 <sup>1</sup> / <sub>8</sub> "- 8	65	453	RR40018
279.4	190.5	108	133	190	28	3"- 12	95	203	1½"- 6	50	14 <sup>1</sup> / <sub>8</sub> "- 8	65	597	RR40024
279.4	190.5	108	133	190	28	3"- 12	95	203	1½"- 6	50	14 <sup>1</sup> / <sub>8</sub> "- 8	65	792	RR40036
279.4	190.5	108	133	190	28	3"- 12	95	203	1½"- 6	50	14 <sup>1</sup> / <sub>8</sub> "- 8	65	980	RR40048
304.8	203.2	120	152	203	28	3¼"- 12	108	203	1¾"- 5	57	15 <sup>5</sup> / <sub>8</sub> "- 8	79	432	RR5006
304.8	203.2	120	152	203	28	3¼"- 12	108	203	1¾"- 5	57	15 <sup>5</sup> / <sub>8</sub> "- 8	79	589	RR50012
304.8	203.2	120	152	203	28	3¼"- 12	108	203	1¾"- 5	57	15 <sup>5</sup> / <sub>8</sub> "- 8	79	680	RR50018
304.8	203.2	120	152	203	28	3¼"- 12	108	203	1¾"- 5	57	15 <sup>5</sup> / <sub>8</sub> "- 8	79	816	RR50024
304.8	203.2	120	152	203	28	3¼"- 12	108	203	1¾"- 5	57	15 <sup>5</sup> / <sub>8</sub> "- 8	79	1002	RR50036
304.8	203.2	120	152	203	28	3¼"- 12	108	203	1¾"- 5	57	15 <sup>5</sup> / <sub>8</sub> "- 8	79	1224	RR50048