

PA Pneumatic Pump (70MPa)

▼ PATG1102N Foot Pneumatic Pump



Maximum Pressure: 70MPa

Air Consumption: 340L/Min

Reservoir Capacity: 1.6L

- Equipped with externally adjustable relief valve (mounted behind the level gauge), built-in relief valve for overload protection.
- Oil tank with integrated return port, suitable for remote valve applications.
- Low air consumption, effectively reducing operating costs.
- Low-noise design, noise level as low as 76dBA, reducing operator fatigue.
- Operating air pressure range 2.8–8.8bar, pump starts at extremely low pressure with strong adaptability.
- High-efficiency cast aluminum pneumatic motor for stable and powerful performance.
- Reinforced heavy-duty oil tank for harsh working environments.
- Composite pneumatic plunger seal, operates normally in completely dry air.
- Supports manual / foot-operated dual-mode operation for flexible and convenient use.

▼ PATG1102N Technical Parameters

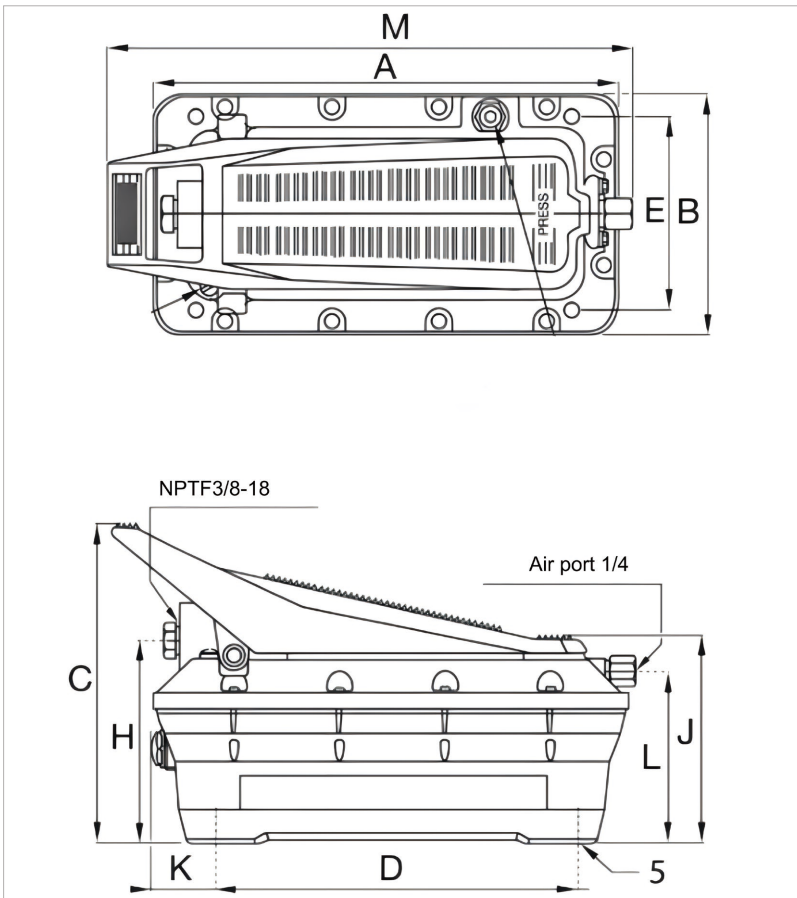

▼ PATG1102N Pressure-Flow Diagram

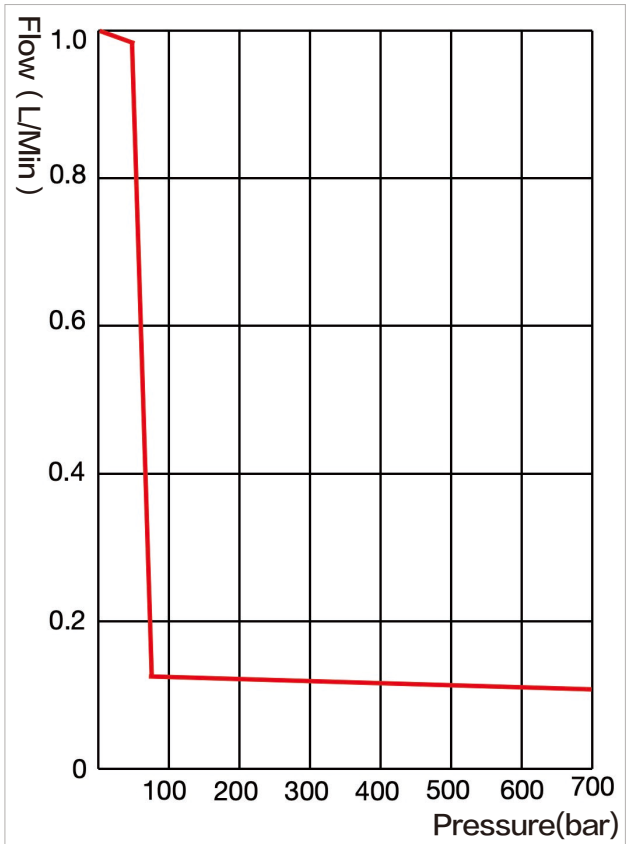

Model	Max Pressure (bar)	Low Pressure Flow (L/Min)	High Pressure Flow (L/Min)	Suitable Cylinder	Oil Capacity (L)	Valve Operation	Dimensions (mm)														Weight (Kg)
							A	B	C	D	E	F	H	J	K	L	M	N			
PATG 1102N	700	1	0.16	Single-Acting	1.6	Treadle 3/3	313	165	211	230	102	-	129	146	42	113	347	-	6.5		