

▼ MXT Square Drive Hydraulic Torque Wrench



Maximum Torque: 112—72000N·m

Accuracy: ±3%

Maximum Working Pressure: 70MPa

- 11 models in this series, with torque range covering 112 N·m to 72000 N·m
- One-piece body made of aluminum-titanium alloy, featuring high strength, high toughness and light weight
- 360°×180° rotating hydraulic tube connector, no space restriction for use, convenient operation
- Square Drive Size with button release for quick switching between tightening and loosening modes
- Trigger-type lock, allowing 360° adjustable reaction arm to be placed on any fixed fulcrum
- Reset trigger design to overcome wrench reversal caused by bolt deformation
- Ratchet and pawl adopt coarse-tooth structure design, with higher tooth strength and better durability

▼ MXT Wrench Technical Specifications

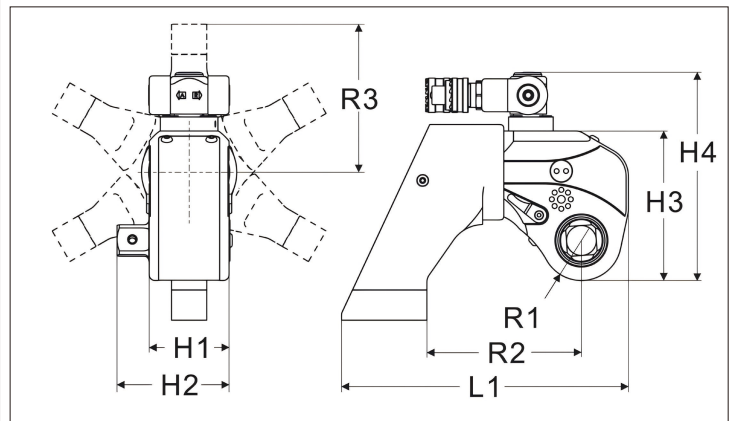
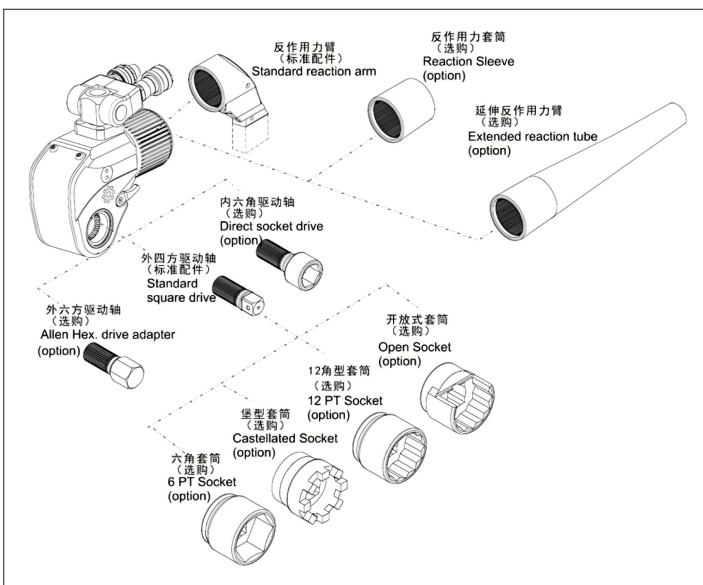

Model	MXT-07	MXT-1	MXT-3	MXT-5	MXT-8	MXT-10	MXT-15	MXT-20	MXT-25	MXT-35	MXT-50
Torque Range (N·m)	112-1120	183-1837	451-4512	752-7528	1078-10780	1551-15516	2063-20627	2666-26664	3472-34725	4866-48666	7200-72000
A/F Size (mm)	22-46	24-55	41-75	41-85	46-95	55-105	60-115	65-130	75-145	95-170	105-180
Weight (Kg)	1.6	2.6	5.4	8.7	11.7	14.8	22	27.8	35.5	49.4	90
L1	139.3	173	244	285.5	311	339.7	395	451	459.2	495.5	418.5
H1	42	50	68	80	90	100	110	120	137	153	160
H2	65.8	72	95.3	123	130.5	140.8	178.7	188.2	200	215.6	222.6
H3	76.2	95.5	127	149	167	182	200.3	220	247	282	290.5
H4	119	138.3	176.5	198.5	216.5	231.5	250	270	296.5	331.5	340
R1	20.5	26	34	39	47	51	55	59	66	77	81
R2	68.3	84.5	131.3	158	171	174	222.5	250.5	250.5	279	258.5
R3	75	91.5	125.8	141	165	170.3	201.5	216.5	224.1	237.6	258
Square Drive Size	3/4"	3/4"	1"	1-1/2"	1-1/2"	1-1/2"	2-1/2"	2-1/2"	2-1/2"	2-1/2"	2-1/2"

▼ XLCT Low Profile Hydraulic Torque Wrench



Maximum Torque: 232-44593N·m

Accuracy: ±3%

Maximum Working Pressure: 70MPa

- 5 different models, with torque range covering 232 N·m to 44593 N·m
- The Link body can be used as a reaction arm
- 360°×180° rotating hydraulic tube connector, no space restriction for use
- Anti-reverse pawl design to prevent wrench from reversing and jamming
- Multiple specifications and models of Links and reducing sleeves to adapt to more working conditions
- Power head with one-piece body made of aluminum-titanium alloy, featuring high strength, high toughness and wear resistance

▼ XLCT Wrench Technical Specifications

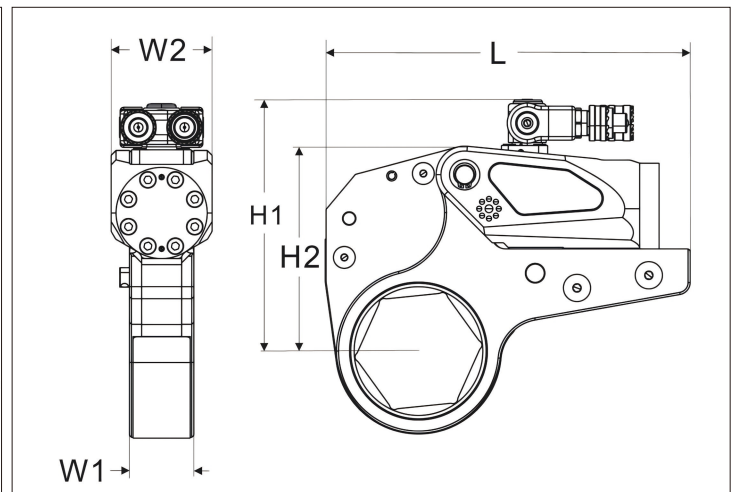
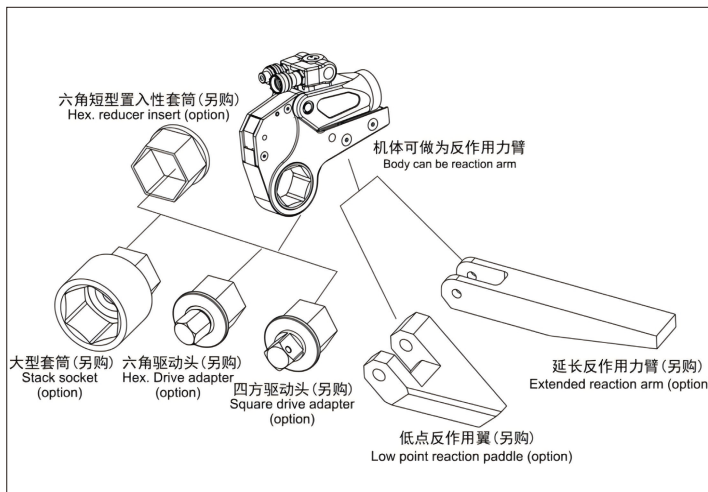

Model	XLCT-2		XLCT-4		XLCT-8		XLCT-14		XLCT-30	
Torque Range (N·m)	232-2328	241-2414	585-2510	585-5858	647-6474	1094-10941	1177-11774	1852-18521	4188-41882	4459-44593
A/F Size (mm)	19-55	60	34-36	41-65	70-80	41-95	100-105	50-117	85-155	160-175
Drive Unit Weight(Kg)	1.2	1.2	2.2	2.2	2.2	3.4	3.4	5.6	12	12
links weight (Kg)	1.6	1.7	4	4.4	4.6	8	8.4	11.6	29	30
L	186	186	245	245	246	300	301	361	420	431
H1	138	141	177	177	187	207	216	239	303	315
H2	102	105	136	136	146	169	178	204	272	285
W1	32	32	42	42	42	53	53	64	85	85
W2	51	51	66	66	66	83	83	99	131	131

▼ Links for XLCT Series

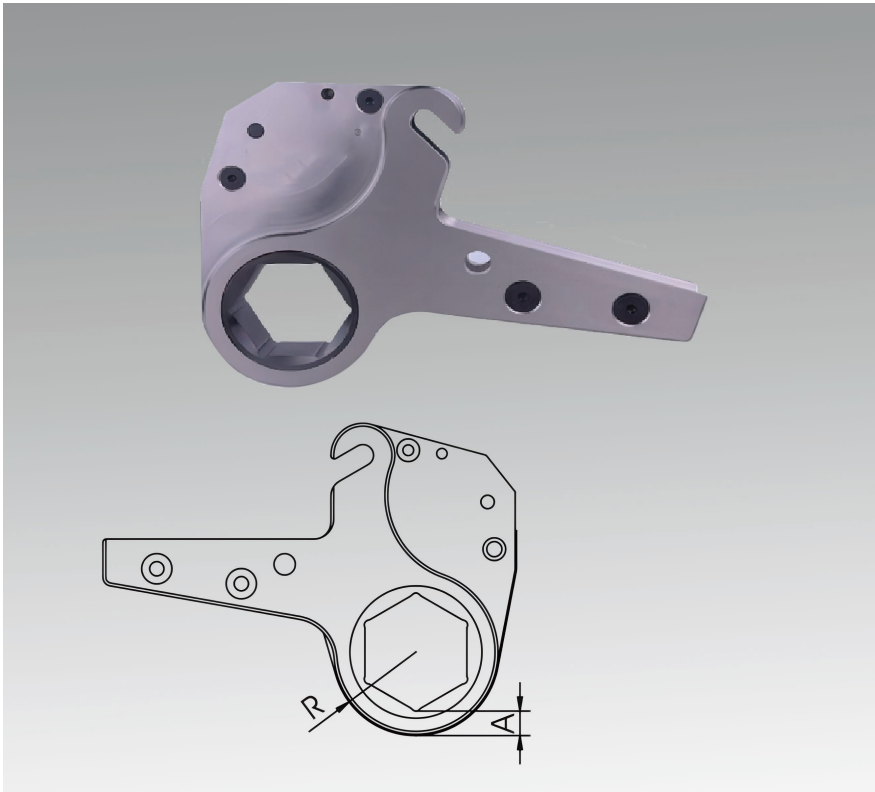

- Each model of XLCT hollow torque wrench power head is equipped with a complete set of Links, covering all sizes of bolts within the torque range provided by the power head of that model.
- When selecting a suitable Link for the bolt, it should be noted that the distance between the bolt and the wall should be greater than the distance between the inner hexagonal side of the Link and the outer edge of the Link.
- Special attention should be paid to whether there is sufficient space between bolts.
- XLCT series Links can be used with reducing sleeves, enabling a single Link to match multiple bolt sizes, greatly improving adaptability and diversity in different working conditions.

Bolt Size (M)	A/F Size (mm)	XLCT-2			XLCT-4			XLCT-8			XLCT-14			XLCT-30		
		Link Model	R (mm)	A (mm)	Link Model	R (mm)	A (mm)	Link Model	R (mm)	A (mm)	Link Model	R (mm)	A (mm)	Link Model	R (mm)	A (mm)
12	19	XLCT-2-S19	27	16	-	-	-	-	-	-	-	-	-	-	-	-
14	22	XLCT-2-S22	27	14	-	-	-	-	-	-	-	-	-	-	-	-
18	27	XLCT-2-S27	27	11	-	-	-	-	-	-	-	-	-	-	-	-
20	30	XLCT-2-S30	29	12	-	-	-	-	-	-	-	-	-	-	-	-
22	32	XLCT-2-S32	29	11	-	-	-	-	-	-	-	-	-	-	-	-
22	34	XLCT-2-S34	31	11	XLCT-4-S34	36	16	-	-	-	-	-	-	-	-	-
24	36	XLCT-2-S36	31	10	XLCT-4-S36	36	15	-	-	-	-	-	-	-	-	-
27	41	XLCT-2-S41	34	10	XLCT-4-S41	39	15	XLCT-8-S41	46	22	-	-	-	-	-	-
30	46	XLCT-2-S46	37	10	XLCT-4-S46	42	15	XLCT-8-S46	46	19	-	-	-	-	-	-
33	50	XLCT-2-S50	40	11	XLCT-4-S50	44	15	XLCT-8-S50	46	17	XLCT-14-S50	60	31	-	-	-
36	55	XLCT-2-S55	43	11	XLCT-4-S55	46	14	XLCT-8-S55	50	18	XLCT-14-S55	60	28	-	-	-
39	60	XLCT-2-S60	46	11	XLCT-4-S60	50	15	XLCT-8-S60	52	17	XLCT-14-S60	60	25	-	-	-
42	65	-	-	-	XLCT-4-S65	53	15	XLCT-8-S65	55	17	XLCT-14-S65	60	22	-	-	-
45	70	-	-	-	XLCT-4-S70	56	15	XLCT-8-S70	58	17	XLCT-14-S70	60	19	-	-	-
48	75	-	-	-	XLCT-4-S75	59	15	XLCT-8-S75	60	17	XLCT-14-S75	63	19	-	-	-
52	80	-	-	-	XLCT-4-S80	61	15	XLCT-8-S80	63	16	XLCT-14-S80	66	19	-	-	-
56	85	-	-	-	-	-	-	XLCT-8-S85	66	16	XLCT-14-S85	69	19	XLCT-30-S85	78	28
60	90	-	-	-	-	-	-	XLCT-8-S90	69	17	XLCT-14-S90	72	20	XLCT-30-S90	78	27
64	95	-	-	-	-	-	-	XLCT-8-S95	71	16	XLCT-14-S95	74	19	XLCT-30-S95	83	28
68	100	-	-	-	-	-	-	XLCT-8-S100	75	17	XLCT-14-S100	77	19	XLCT-30-S100	83	25
72	105	-	-	-	-	-	-	XLCT-8-S105	78	17	XLCT-14-S105	80	19	XLCT-30-S105	89	28
76	110	-	-	-	-	-	-	-	-	-	XLCT-14-S110	83	19	XLCT-30-S110	89	25
80	115	-	-	-	-	-	-	-	-	-	XLCT-14-S115	87	20	XLCT-30-S115	95	28
85	117	-	-	-	-	-	-	-	-	-	XLCT-14-S117	87	19	XLCT-30-S117	95	27
85	125	-	-	-	-	-	-	-	-	-	-	-	-	XLCT-30-S125	101	29
90	130	-	-	-	-	-	-	-	-	-	-	-	-	XLCT-30-S130	101	26
95	135	-	-	-	-	-	-	-	-	-	-	-	-	XLCT-30-S135	104	26
100	140	-	-	-	-	-	-	-	-	-	-	-	-	XLCT-30-S140	110	29
100	145	-	-	-	-	-	-	-	-	-	-	-	-	XLCT-30-S145	110	26
105	150	-	-	-	-	-	-	-	-	-	-	-	-	XLCT-30-S150	116	29
110	155	-	-	-	-	-	-	-	-	-	-	-	-	XLCT-30-S155	116	26
110	160	-	-	-	-	-	-	-	-	-	-	-	-	XLCT-30-S160	128	36
115	165	-	-	-	-	-	-	-	-	-	-	-	-	XLCT-30-S165	128	33
120	170	-	-	-	-	-	-	-	-	-	-	-	-	XLCT-30-S170	128	30
-	175	-	-	-	-	-	-	-	-	-	-	-	-	XLCT-30-S175	128	27

▼ AVANTI Hydraulic Torque Wrenches



Maximum Torque: 151-15921N·m

Accuracy: ±3%

Maximum Working Pressure: 70MPa

- One-piece body made of aluminum-titanium alloy, featuring high strength and high toughness
- Square Drive Size adopts coaxial double-layer spline design, the front reaction arm is combined with the Square Drive Size along the bolt axis, which can rotate 360°
- 6 models in this series, with torque range covering 151 N·m to 15921 N·m
- 360°×180° rotating hydraulic tube connector, meeting the freedom of

▼ AVANTI Wrench Technical Specifications

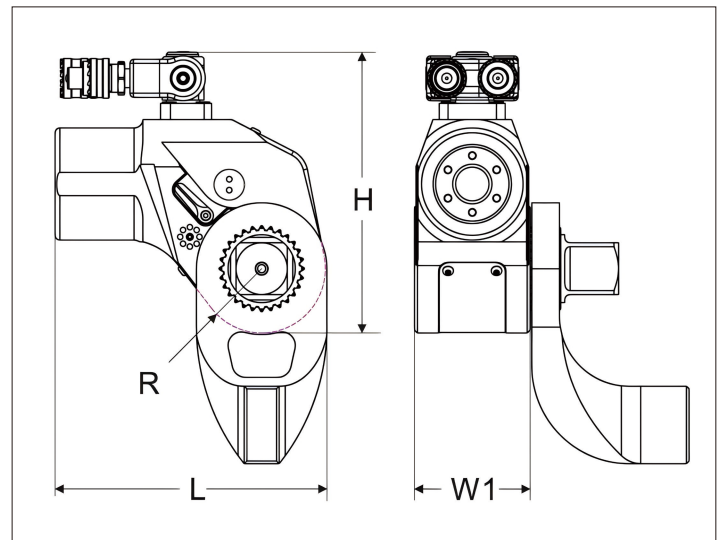
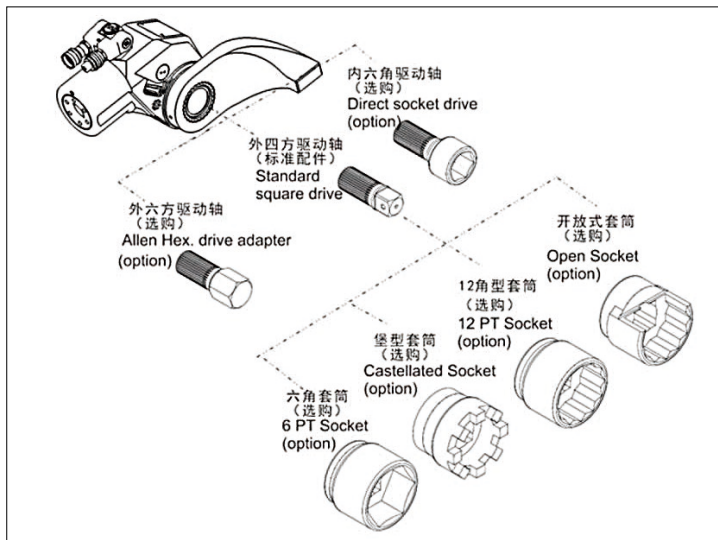

Model	AVANTI-07	AVANTI-1	AVANTI-3	AVANTI-5	AVANTI-8	AVANTI-10
Torque Range (N·m)	151-1058	249-1741	424-4241	737-7370	1052-10521	1592-15921
Weight (Kg)	1.4	2	4.3	7.1	9.4	13.3
L(mm)	111	128	165.8	202	224	251.7
H(mm)	120	140.8	180	206.5	227.8	248.1
R(mm)	25.4	28.6	38.1	47.3	52.3	60.1
W1(mm)	46	55.2	73.7	86	100.5	110.5
Square Drive Size	3/4"	3/4"	1"	1-1/2"	1-1/2"	1-1/2"

▼ RGH Hollow Hydraulic Torque Wrenches



Maximum Torque: 223-30408N·m

Accuracy: ±3%

Maximum Working Pressure: 70MPa

- 5 models, with torque range covering 223 - 30408 N·m
- Flat design, the thickness of the power head and Link is the same, excellent for narrow space applications
- 360°×180° rotation allows the wrench to be operated freely without space restrictions
- The wrench acts directly on the nut, with higher accuracy and more convenient operation
- Power head made of high-strength alloy steel, featuring high strength, wear resistance and compact design

▼ RGH Wrench Technical Specifications

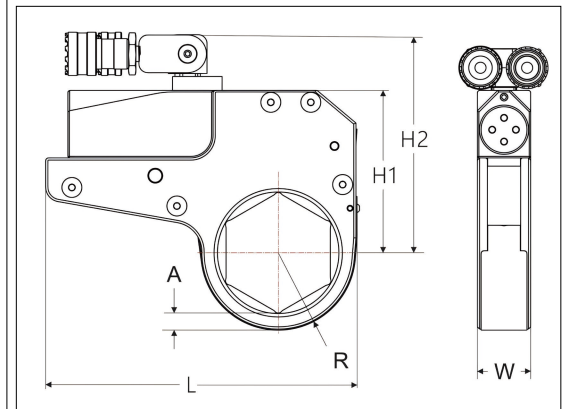
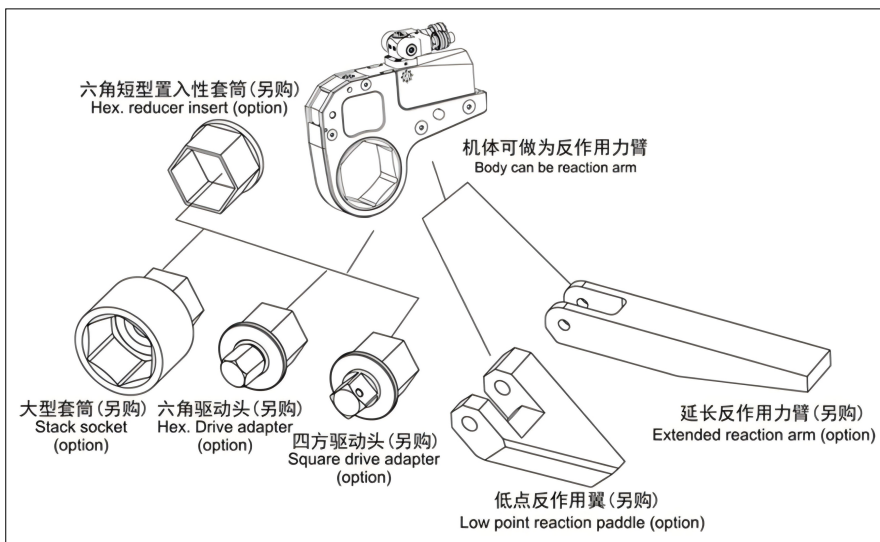

Model	RGH-2		RGH-3		RGH-4		RGH-8		RGH-14		RGH-22
Torque Range (N·m)	223-2235	232-2328	314-2245	314-3143	585-2509	585-5858	647-6474	1094-10941	1177-11774	1852-18521	3041-30408
Maximum Pressure (MPa)	70	70	50	70	30	70	70	70	70	70	70
A/F Size(mm)	19-55	60	27-41	46-70	34-36	41-65	70-80	41-95	100-105	50-117	75-135
Drive Unit Weight(Kg)	1.2	1.2	1.4	1.4	1.6	1.6	1.6	3.1	3.1	4.8	7.8
Links Weight (Kg)	1.5	1.8	1.7	2	4	4.3	4.5	8.1	8.9	13.5	23.9
L(mm)	186	186	207	207/210	241	245	246	300	300	361	412
H1(mm)	95	98	110	110	127	127	137	156	165	188	220
H2(mm)	133	136	153	153	177	177	187	206	215	238	270
W(mm)	32	32	36	36	43	43	43	53	53	64	77

▼ Links for RGH Series

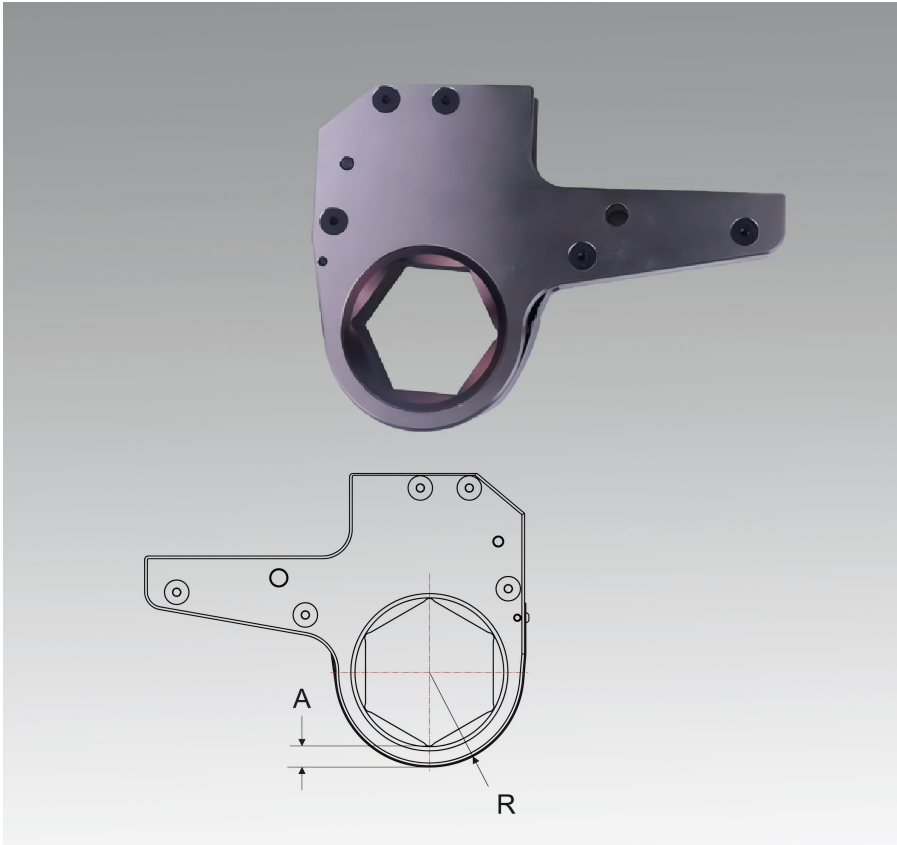

- Each model of RGH hollow torque wrench power head is equipped with a complete set of Links, covering all sizes of bolts within the torque range provided by the power head of that model.
- When selecting a suitable Link for the bolt, it should be noted that the distance between the bolt and the wall should be greater than the distance between the inner hexagonal side of the Link and the outer edge of the Link.
- Special attention should be paid to whether there is sufficient space between bolts.
- RGH series Links can be used with reducing sleeves, enabling a single Link to match multiple bolt sizes, greatly improving adaptability and diversity in different working conditions.

Bolt Size (M)	A/F Size (mm)	RGH-2			RGH-3			RGH-4			RGH-8			RGH-14			RGH-22		
		Link Model	R (mm)	A (mm)	Link Model	R (mm)	A (mm)	Link Model	R (mm)	A (mm)	Link Model	R (mm)	A (mm)	Link Model	R (mm)	A (mm)	Link Model	R (mm)	A (mm)
12	19	RGH-2-S19	27	16	-	-	-	-	-	-	-	-	-	-	-	-	-	-	-
14	22	RGH-2-S22	27	14	-	-	-	-	-	-	-	-	-	-	-	-	-	-	-
18	27	RGH-2-S27	27	11	RGH-3-S27	34	19	-	-	-	-	-	-	-	-	-	-	-	-
20	30	RGH-2-S30	29	12	RGH-3-S30	34	17	-	-	-	-	-	-	-	-	-	-	-	-
22	32	RGH-2-S32	29	11	RGH-3-S32	34	16	-	-	-	-	-	-	-	-	-	-	-	-
22	34	RGH-2-S34	31	11	RGH-3-S34	34	15	RGH-4-S34	36	16	-	-	-	-	-	-	-	-	-
24	36	RGH-2-S36	31	10	RGH-3-S36	34	13	RGH-4-S36	36	15	-	-	-	-	-	-	-	-	-
27	41	RGH-2-S41	34	10	RGH-3-S41	37	13	RGH-4-S41	39	15	RGH-8-S41	46	22	-	-	-	-	-	-
30	46	RGH-2-S46	37	10	RGH-3-S46	40	13	RGH-4-S46	42	15	RGH-8-S46	46	19	-	-	-	-	-	-
33	50	RGH-2-S50	40	11	RGH-3-S50	43	14	RGH-4-S50	44	15	RGH-8-S50	46	17	RGH-14-S50	60	31	-	-	-
36	55	RGH-2-S55	43	11	RGH-3-S55	45	13	RGH-4-S55	46	14	RGH-8-S55	50	18	RGH-14-S55	60	28	-	-	-
39	60	RGH-2-S60	45	10	RGH-3-S60	48	13	RGH-4-S60	50	15	RGH-8-S60	52	17	RGH-14-S60	60	25	-	-	-
42	65	-	-	-	RGH-3-S65	51	13	RGH-4-S65	53	15	RGH-8-S65	55	17	RGH-14-S65	60	22	-	-	-
45	70	-	-	-	RGH-3-S70	53	13	RGH-4-S70	56	15	RGH-8-S70	58	17	RGH-14-S70	63	19	-	-	-
48	75	-	-	-	-	-	-	RGH-4-S75	59	15	RGH-8-S75	60	17	RGH-14-S75	60	19	RGH-22-S75	73	30
52	80	-	-	-	-	-	-	RGH-4-S80	61	15	RGH-8-S80	63	16	RGH-14-S80	66	19	RGH-22-S80	73	27
56	85	-	-	-	-	-	-	-	-	-	RGH-8-S85	66	16	RGH-14-S85	69	19	RGH-22-S85	73	24
60	90	-	-	-	-	-	-	-	-	-	RGH-8-S90	69	17	RGH-14-S90	72	20	RGH-22-S90	79	27
64	95	-	-	-	-	-	-	-	-	-	RGH-8-S95	71	16	RGH-14-S95	74	19	RGH-22-S95	79	24
68	100	-	-	-	-	-	-	-	-	-	RGH-8-S100	75	17	RGH-14-S100	77	19	RGH-22-S100	85	27
72	105	-	-	-	-	-	-	-	-	-	RGH-8-S105	78	17	RGH-14-S105	80	19	RGH-22-S105	85	24
76	110	-	-	-	-	-	-	-	-	-	-	-	-	RGH-14-S110	83	19	RGH-22-S110	92	28
80	115	-	-	-	-	-	-	-	-	-	-	-	-	RGH-14-S115	87	20	RGH-22-S115	92	26
85	117	-	-	-	-	-	-	-	-	-	-	-	-	RGH-14-S117	87	19	RGH-22-S117	92	25
85	120	-	-	-	-	-	-	-	-	-	-	-	-	-	-	-	RGH-22-S120	97	28
90	130	-	-	-	-	-	-	-	-	-	-	-	-	-	-	-	RGH-22-S130	102	27
95	135	-	-	-	-	-	-	-	-	-	-	-	-	-	-	-	RGH-22-S135	102	24
100	140	-	-	-	-	-	-	-	-	-	-	-	-	-	-	-	-	-	-
105	145	-	-	-	-	-	-	-	-	-	-	-	-	-	-	-	-	-	-
110	155	-	-	-	-	-	-	-	-	-	-	-	-	-	-	-	-	-	-
110	160	-	-	-	-	-	-	-	-	-	-	-	-	-	-	-	-	-	-
115	165	-	-	-	-	-	-	-	-	-	-	-	-	-	-	-	-	-	-
120	170	-	-	-	-	-	-	-	-	-	-	-	-	-	-	-	-	-	-
	175	-	-	-	-	-	-	-	-	-	-	-	-	-	-	-	-	-	-

▼ RTO Hydraulic Torque Wrenches

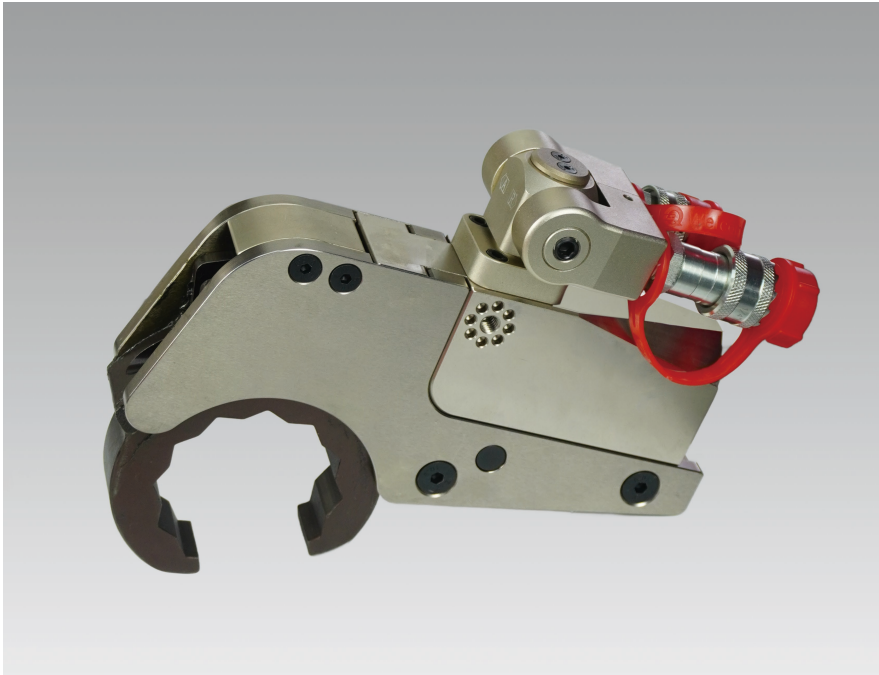

Maximum Torque: 184-17219N·m

Accuracy: ±3%

Maximum Working Pressure: 70MPa

- 6 models in this series, with torque range covering 184 N·m to 17219 N·m
- Flat design, the thickness of the power head and working head is the same, excellent for narrow space applications
- 360°×180° rotation allows the wrench to be operated freely without space restrictions
- The wrench acts directly on the nut, with higher accuracy and more convenient operation
- Power head made of high-strength alloy steel, featuring high strength, wear resistance and compact design

▼ RTO Wrench Technical Specifications

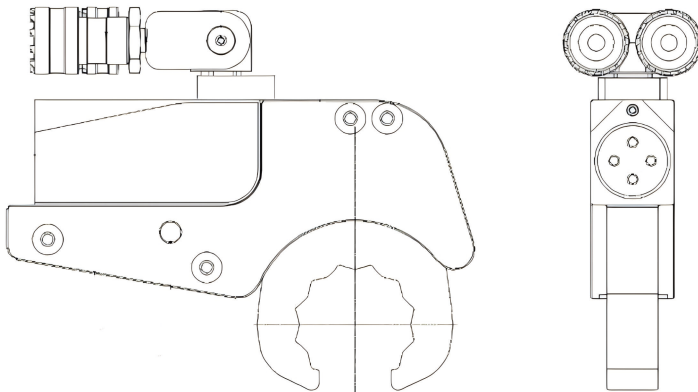

Model			RTO-2	RTO-3	RTO-4	RTO-8	RTO-14	RTO-22
A/F Size(mm)			27-55	27-65	34-75	41-90	50-100	75-120
MPa	bar	psi	N.m	N·m	N·m	N·m	N·m	N·m
7	70	1015	184	269	462	884	1234	1722
8	80	1160	211	307	528	1011	1411	1968
9	90	1305	237	346	594	1137	1587	2214
10	100	1450	263	384	660	1263	1763	2460
11	110	1595	289	422	726	1390	1940	2706
12	120	1740	316	461	792	1516	2116	2952
13	130	1885	342	499	858	1642	2292	3198
14	140	2030	368	538	924	1769	2469	3444
15	150	2175	395	576	990	1895	2645	3690
16	160	2320	421	614	1056	2021	2821	3936
17	170	2465	447	653	1122	2148	2998	4182
18	180	2610	474	691	1188	2274	3174	4428
19	190	2755	500	730	1254	2401	3350	4674
20	200	2900	526	768	1320	2527	3527	4920
21	210	3045	553	806	1386	2653	3703	5166

Model			RTO-2	RTO-3	RTO-4	RTO-8	RTO-14	RTO-22
A/F Size(mm)			27-55	27-65	34-75	41-90	50-100	75-120
MPa	bar	psi	N·m	N·m	N·m	N·m	N·m	N·m
22	220	3190	579	845	1452	2780	3879	5412
23	230	3335	605	883	1518	2906	4056	5658
24	240	3480	632	922	1584	3032	4232	5904
25	250	3625	658	960	1650	3159	4408	6150
26	260	3770	684	998	1716	3285	4585	6396
27	270	3915	710	1037	1782	3411	4761	6642
28	280	4060	737	1075	1848	3538	4937	6888
29	290	4205	763	1114	1914	3664	5114	7134
30	300	4350	789	1152	1980	3790	5290	7380
31	310	4495	816	1190	2046	3917	5466	7626
32	320	4640	842	1229	2112	4043	5642	7872
33	330	4785	868	1267	2178	4169	5819	8118
34	340	4930	895	1306	2244	4296	5995	8364
35	350	5075	921	1344	2310	4422	6171	8609
36	360	5220	947	1382	2376	4548	6348	8855
37	370	5365	974	1421	2442	4675	6524	9101
38	380	5510	1000	1459	2508	4801	6700	9347
39	390	5655	1026	1498	2574	4927	6877	9593
40	400	5800	1053	1536	2640	5054	7053	9839
41	410	5945	1079	1574	2706	5180	7229	10085
42	420	6090	1105	1613	2772	5306	7406	10331
43	430	6235	1132	1651	2838	5433	7582	10577
44	440	6380	1158	1690	2904	5559	7758	10823
45	450	6525	1184	1728	2970	5685	7935	11069
46	460	6670	1210	1766	3036	5812	8111	11315
47	470	6815	1237	1805	3102	5938	8287	11561
48	480	6960	1263	1843	3168	6064	8464	11807
49	490	7105	1289	1882	3234	6191	8640	12053
50	500	7250	1316	1920	3300	6317	8816	12299
51	510	7395	1342	1958	3366	6443	8993	12545
52	520	7540	1368	1997	3432	6570	9169	12791
53	530	7685	1395	2035	3498	6696	9345	13037
54	540	7830	1421	2074	3564	6823	9522	13283
55	550	7975	1447	2112	3630	6949	9698	13529
56	560	8120	1474	2150	3696	7075	9874	13775
57	570	8265	1500	2189	3762	7202	10051	14021
58	580	8410	1526	2227	3828	7328	10227	14267
59	590	8555	1553	2266	3894	7454	10403	14513
60	600	8700	1579	2304	3960	7581	10580	14759
61	610	8845	1605	2342	4026	7707	10756	15005
62	620	8990	1631	2381	4092	7833	10932	15251
63	630	9135	1658	2419	4158	7960	11109	15497
64	640	9280	1684	2458	4224	8086	11285	15743
65	650	9425	1710	2496	4290	8212	11461	15989
66	660	9570	1737	2534	4356	8339	11638	16235
67	670	9715	1763	2573	4422	8465	11814	16481
68	680	9860	1789	2611	4488	8591	11990	16727
69	690	10005	1816	2650	4554	8718	12167	16973
70	700	10150	1842	2688	4620	8844	12343	17219

Hydraulic Torque Wrenches

▼ Sleeve



- Made of high-strength alloy steel
- Black oxide finish on the surface
- Can be specially customized according to on-site conditions

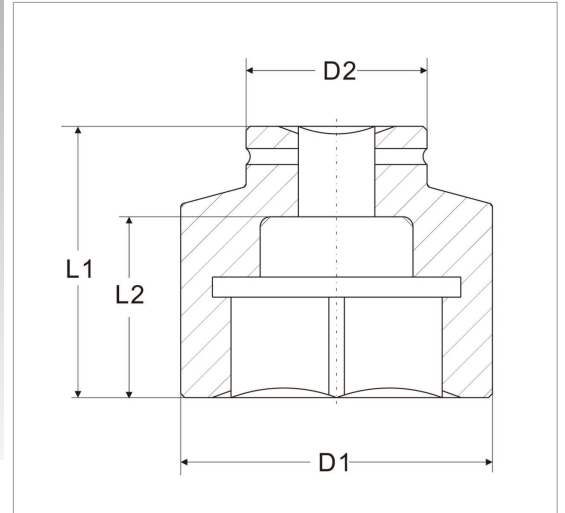

▼ Sleeve Technical Specifications

Bolt Size (M)	Across Flats (mm)	3/4"(19×19)					1"(25×25)				1-1/2"(38×38)				2-1/2"(63×63)							
		Model	D1 (mm)	D2 (mm)	L1 (mm)	L2 (mm)	Model	D1 (mm)	D2 (mm)	L1 (mm)	L2 (mm)	Model	D1 (mm)	D2 (mm)	L1 (mm)	L2 (mm)	Model	D1 (mm)	D2 (mm)	L1 (mm)	L2 (mm)	
M16	24	R19S24	40	40	54	33	-	-	-	-	-	-	-	-	-	-	-	-	-	-	-	-
M18	27	R19S27	42	42	54	33	-	-	-	-	-	-	-	-	-	-	-	-	-	-	-	-
M20	30	R19S30	46	42	54	33	R25S30	54	54	59	32	-	-	-	-	-	-	-	-	-	-	-
							R25S32	53	59	58	31	-	-	-	-	-	-	-	-	-	-	-
M22	34	R19S34	50	44	54	32	R25S34	54	54	59	32											
M24	36	R19S36	53	44	57	34	R25S36	54	54	62	34	R38S36	60	69	85	45	-	-	-	-	-	-
M27	41	R19S41	60	44	58	35	R25S41	63	54	65	37	-	-	-	-	-	-	-	-	-	-	-
M30	46	R19S46	66	44	63	40	R25S46	68	54	65	37	R38S46	69	69	85	45	-	-	-	-	-	-
M33	50	R19S50	71	44	65	40	R25S50	74	60	70	43	R38S50	79	79	90	50	-	-	-	-	-	-
M36	55	R19S55	78	54	70	45	R25S55	79	60	80	52	R38S55	79	79	90	50	R63S55	84	109	110	52	
M39	60	R19S60	84	54	85	57	R25S60	84	60	85	57	R38S60	88	88	100	60	R63S60	106	109	110	52	
M42	65	R19S65	89	54	85	57	R25S65	94	70	85	57	R38S65	98	80	100	60	R63S65	106	109	110	42	
M45	70	R19S70	99	54	90	62	R25S70	98	70	90	62	R38S70	98	80	105	60	R63S70	119	119	120	40	
M48	75	R19S75	99	54	95	67	R25S75	108	70	95	67	R38S75	108	85	110	65	R63S75	119	119	120	40	
M52	80						R25S80	113	70	95	67	R38S80	118	90	115	70	R63S80	119	119	130	45	
M56	85	R19S85	113	54	110	80	R25S85	118	70	108	77	R38S85	118	90	125	80	R63S85	119	119	130	71	
M60	90											R38S90	129	90	125	80	R63S90	128	119	140	73	
M64	95	R19S95	124	54	115	85	R25S95	128	70	118	85	R38S95	129	90	130	85	R63S95	128	119	140	73	
M68	100	-	-	-	-	-	-	-	-	-	-	R38S100	138	90	135	90	R63S100	138	119	140	81	
M72	105	-	-	-	-	-	-	-	-	-	-	R38S105	147	90	135	90	R63S105	138	119	150	89	
M76	110	-	-	-	-	-	-	-	-	-	-	R38S110	147	90	135	90	R63S110	147	119	150	90	
M80	115	-	-	-	-	-	-	-	-	-	-	R38S115	158	90	135	90	R63S115	158	119	150	92	
M85	120	-	-	-	-	-	-	-	-	-	-	R38S120	158	95	135	90	R63S120	168	127	150	92	
M90	130	-	-	-	-	-	-	-	-	-	-	R38S130	175	95	155	100	R63S130	178	127	170	98	
M95	135	-	-	-	-	-	-	-	-	-	-	-	-	-	-	-	R63S135	188	127	170	105	
M100	145	-	-	-	-	-	-	-	-	-	-	-	-	-	-	-	R63S145	198	127	170	105	
M105	150	-	-	-	-	-	-	-	-	-	-	-	-	-	-	-	R63S150	216	127	190	125	
M110	155	-	-	-	-	-	-	-	-	-	-	-	-	-	-	-	R63S155	226	150	190	125	
M115	165	-	-	-	-	-	-	-	-	-	-	-	-	-	-	-	R63S165	236	150	210	130	

▼ Reducing Sleeve

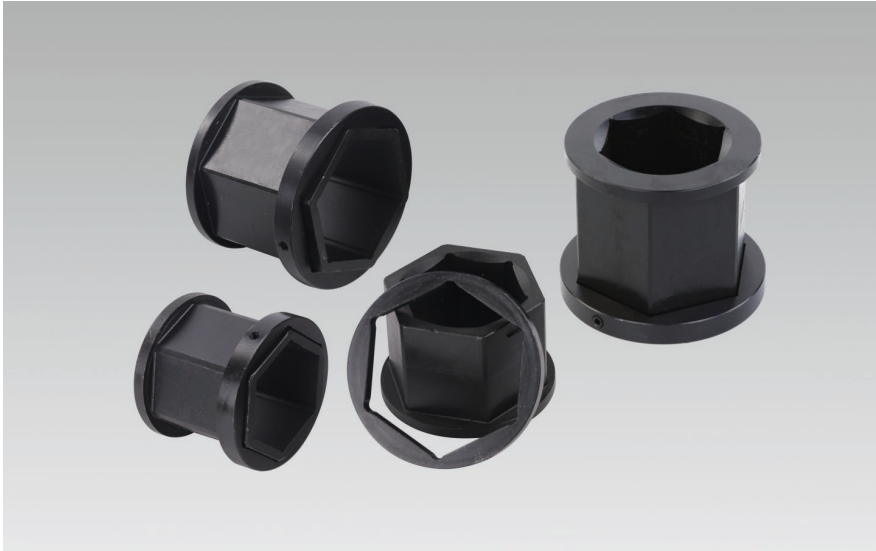

- Made of high-strength alloy steel
- Black oxide finish on the surface
- Can be specially customized according to on-site conditions

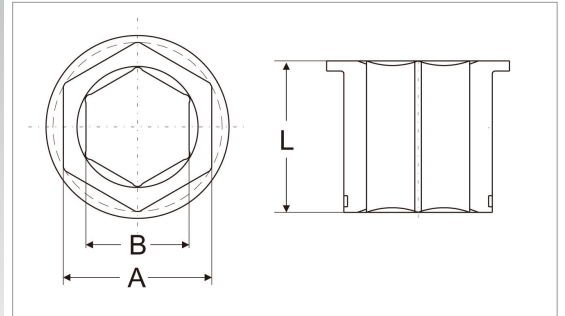

▼ Reducing Sleeve Technical Specifications

Model	Dimensions (mm)			Model	Dimensions (mm)			Model	Dimensions (mm)			Model	Dimensions (mm)			Model	Dimensions (mm)		
	A	B	L		A	B	L		A	B	L		A	B	L		A	B	L
XLCT2-32-27	32	27	50	XLCT3-65-60	65	60	54	XLCT8-60-46	60	46	71	XLCT14-100-90	100	90	82	XLCT30-85-75	85	75	103
XLCT2-36-27	36	27	50	XLCT3-70-60	70	60	54	XLCT8-60-50	60	50	71	XLCT14-105-90	105	90	82	XLCT30-90-75	90	75	103
XLCT2-36-30	36	30	50	XLCT3-70-65	70	65	54	XLCT8-65-50	65	50	71	XLCT14-105-95	105	95	82	XLCT30-90-80	90	80	103
XLCT2-41-30	41	30	50	XLCT4-32-27	32	27	60	XLCT8-65-55	65	55	71	XLCT14-110-95	110	95	82	XLCT30-95-80	95	80	103
XLCT2-41-32	41	32	50	XLCT4-36-27	36	27	60	XLCT8-70-55	70	55	71	XLCT14-110-100	110	100	82	XLCT30-95-85	95	85	103
XLCT2-46-32	46	32	50	XLCT4-36-30	36	30	60	XLCT8-70-60	70	60	71	XLCT14-117-100	115	100	82	XLCT30-100-85	100	85	103
XLCT2-46-36	46	36	50	XLCT4-41-30	41	30	60	XLCT8-75-60	75	60	71	XLCT14-117-105	115	105	82	XLCT30-100-90	100	90	103
XLCT2-50-36	50	36	50	XLCT4-41-32	41	32	60	XLCT8-75-65	75	65	71	XLCT22-75-65	75	65	92	XLCT30-105-90	105	90	103
XLCT2-50-41	50	41	50	XLCT4-46-32	46	32	60	XLCT8-80-65	80	65	71	XLCT22-80-65	80	65	92	XLCT30-105-95	105	95	103
XLCT2-55-46	55	45	50	XLCT4-46-36	46	36	60	XLCT8-80-70	80	70	71	XLCT22-80-70	80	70	92	XLCT30-110-95	110	95	103
XLCT2-55-50	55	50	50	XLCT4-50-36	50	36	60	XLCT8-85-70	85	70	71	XLCT22-85-70	85	70	92	XLCT30-110-100	110	100	103
XLCT2-60-50	60	50	50	XLCT4-50-41	50	41	60	XLCT8-85-75	85	75	71	XLCT22-85-75	85	75	92	XLCT30-117-100	117	100	103
XLCT2-60-55	60	55	50	XLCT4-55-41	55	41	60	XLCT8-90-75	90	75	71	XLCT22-90-75	90	75	92	XLCT30-117-105	117	105	103
XLCT3-36-27	36	27	54	XLCT4-55-46	55	46	60	XLCT8-90-80	90	80	71	XLCT22-90-80	90	80	92	XLCT30-120-110	120	110	103
XLCT3-36-30	36	30	54	XLCT4-60-46	60	46	60	XLCT8-95-80	95	80	71	XLCT22-95-80	95	80	92	XLCT30-120-115	120	115	103
XLCT3-41-30	41	30	54	XLCT4-60-50	60	50	60	XLCT8-95-85	95	85	71	XLCT22-95-85	95	85	92	XLCT30-130-117	130	117	103
XLCT3-41-32	41	32	54	XLCT4-65-50	65	50	60	XLCT14-75-65	75	65	82	XLCT22-100-85	100	85	92	XLCT30-130-120	130	120	103
XLCT3-46-36	46	36	54	XLCT4-65-55	65	55	60	XLCT14-80-65	80	65	82	XLCT22-100-90	100	90	92	XLCT30-135-120	135	120	103
XLCT3-46-41	46	41	54	XLCT4-70-55	70	55	60	XLCT14-80-70	80	70	82	XLCT22-105-90	105	90	92	XLCT30-135-125	135	125	103
XLCT3-50-41	50	41	54	XLCT4-70-60	70	60	60	XLCT14-85-70	85	70	82	XLCT22-105-95	105	95	92	XLCT30-140-125	140	125	103
XLCT3-50-46	50	46	54	XLCT4-75-60	75	60	60	XLCT14-85-75	85	75	82	XLCT22-117-105	117	105	92	XLCT30-140-130	140	130	103
XLCT3-55-46	55	46	54	XLCT4-75-65	75	65	60	XLCT14-90-75	90	75	82	XLCT22-117-110	117	110	92	XLCT30-145-130	145	130	103
XLCT3-55-50	55	50	54	XLCT4-80-65	80	65	60	XLCT14-90-80	90	80	82	XLCT22-130-115	130	115	92	XLCT30-145-135	145	135	103
XLCT3-60-50	60	50	54	XLCT4-80-70	80	70	60	XLCT14-95-80	95	80	82	XLCT22-130-120	130	120	92	XLCT30-150-135	150	135	103
XLCT3-60-55	60	55	54	XLCT8-55-41	55	41	71	XLCT14-95-85	95	85	82	XLCT22-135-120	135	120	92	XLCT30-150-140	150	140	103
XLCT3-65-55	65	55	54	XLCT8-55-46	55	46	71	XLCT14-100-85	100	85	82	XLCT22-135-125	135	125	92	XLCT30-155-145	155	145	103