

▼ HRC 通用型单作用液压油缸



额定压力: 70MPa

额定吨位: 5-95ton

行程范围: 16-362mm

► 注释

- HRC50 液压油缸的沟槽鞍座不可拆卸, 没有外环螺纹
- HRC50: D1=41mm, L=20mm, M=25mm
- HRC101 的柱塞配有两个螺纹孔和一个不可拆卸的鞍座

- 强化设计的止动环, 提高耐用性和抗偏载能力
- 大吨位油缸配置经过认证的 G80 高强度吊环
- 所有型号配置底座安装孔
- 配置呼吸口, 平缓推出, 快速回程
- 预张紧弹簧系统, 回缩速度更快
- 采用高等级聚氨酯密封件, 密封性能好, 耐磨损, 使用寿命长
- 柱塞防尘圈可减少污染问题, 延长液压油缸的使用寿命
- 预设外环螺纹、柱塞螺纹和底座安装孔, 连接安装更简单
- 可用于所有安装位置与方向
- 所有零部件采用气体氮化和后氧化工艺表面处理, 提供更加优秀的防腐性能和抗偏载性能

▼ HRC 油缸性能介绍:

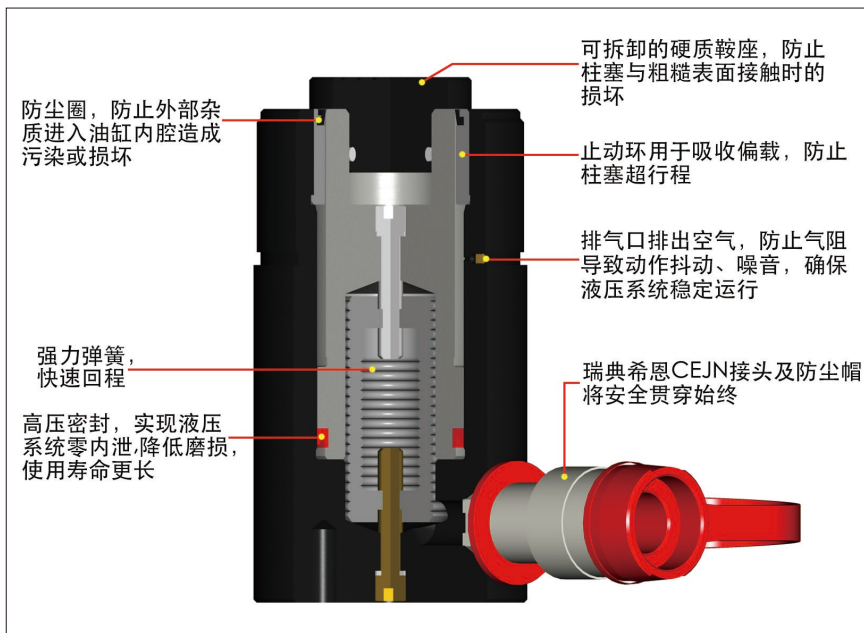

承载能力 ton (kN)	行程 (mm)	型号	油缸有效面积 (cm ²)	油量 (cm ³)	收缩高度 A (mm)	伸展高度 B (mm)
5 (45)	16	HRC50	6.4	10	41	57
	25	HRC51	6.4	16	110	135
	79	HRC53	6.4	50	165	244
	127	HRC55	6.4	83	216	343
	177	HRC57	6.4	115	273	450
10 (101)	232	HRC59	6.4	151	324	556
	26	HRC101	14.4	38	90	116
	54	HRC102	14.4	78	121	175
	105	HRC104	14.4	152	171	276
	156	HRC106	14.4	226	248	404
	203	HRC108	14.4	294	298	501
	257	HRC1010	14.4	373	349	606
	304	HRC1012	14.4	441	400	704
	356	HRC1014	14.4	516	451	807
	15 (142)	25	HRC151	20.3	51	124
51		HRC152	20.3	104	149	200
101		HRC154	20.3	205	200	301
152		HRC156	20.3	308	271	423
203		HRC158	20.3	411	322	525
254		HRC1510	20.3	516	373	627
305		HRC1512	20.3	619	424	729
356		HRC1514	20.3	723	475	831
25 (232)	26	HRC251	33.3	86	140	166
	50	HRC252	33.3	166	165	215
	102	HRC254	33.3	339	216	318
	158	HRC256	33.3	525	273	431
	210	HRC258	33.3	697	324	534
	261	HRC2510	33.3	867	375	636
	311	HRC2512	33.3	1033	425	736
362	HRC2514	33.3	1202	476	838	
30 (295)	209	HRC308	42.9	880	387	596
50 (498)	51	HRC502	71.3	362	176	227
	101	HRC504	71.3	719	227	328
	159	HRC506	71.3	1131	283	442
	260	HRC5010	71.3	1855	384	644
75 (718)	337	HRC5013	71.3	2399	460	797
	156	HRC756	102.6	1601	286	442
	333	HRC7513	102.6	3417	492	825
95 (933)	51	HRC1002	133.1	676	219	270
	168	HRC1006	133.1	2239	357	525
	260	HRC10010	133.1	3466	449	709

▼ HRC 外形尺寸图：

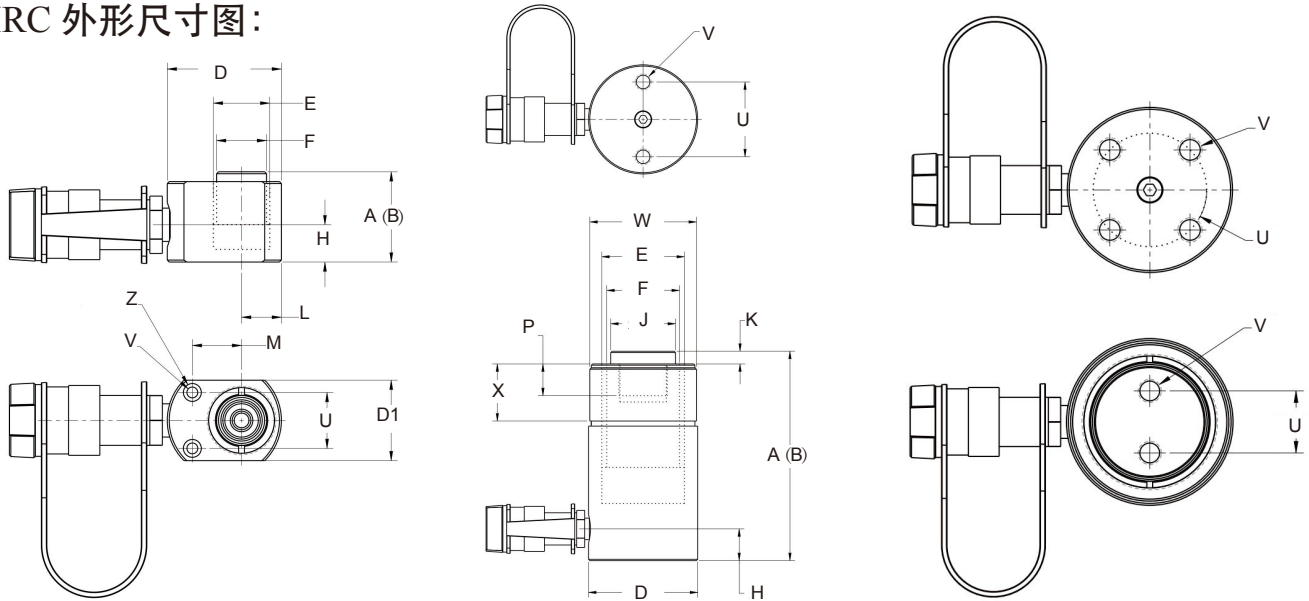

外径 D (mm)	油缸内径 E (mm)	柱塞直径 F (mm)	进油口距底部高度 H (mm)	鞍座直径 J (mm)	鞍座凸出高度 K (mm)	柱塞内螺纹 O	柱塞螺纹长度 P (mm)	底座安装孔			外环螺纹 W	外环螺纹长度 X (mm)	重量 (KG)	型号
								螺栓分布圆 U (mm)	螺纹 V	螺纹深度 Z (mm)				
58	28.6	25.4	19	—	—	—	—	29	5.6 mm	—	—	—	1	HRC50
38	28.6	25.4	19	25	6	3/4" - 16 UN	14	25	1/4" - 20 UNC	14	1 1/2" - 16 UN	28	1	HRC51
38	28.6	25.4	19	25	6	3/4" - 16 UN	14	25	1/4" - 20 UNC	14	1 1/2" - 16 UN	28	1.5	HRC53
38	28.6	25.4	19	25	6	3/4" - 16 UN	14	25	1/4" - 20 UNC	14	1 1/2" - 16 UN	28	1.9	HRC55
38	28.6	25.4	19	25	6	3/4" - 16 UN	16	25	1/4" - 20 UNC	14	1 1/2" - 16 UN	28	2.4	HRC57
38	28.6	25.4	19	25	6	3/4" - 16 UN	16	25	1/4" - 20 UNC	14	1 1/2" - 16 UN	28	2.8	HRC59
57	42.8	38.1	19	—	—	#10 - 24 UN	6	40	5/16" - 18 UNC	12	2 1/4" - 14 UN	27	1.8	HRC101
57	42.8	38.1	19	35	6	1" - 8 UN	19	40	5/16" - 18 UNC	12	2 1/4" - 14 UN	27	2.3	HRC102
57	42.8	38.1	19	35	6	1" - 8 UN	19	40	5/16" - 18 UNC	12	2 1/4" - 14 UN	27	3.3	HRC104
57	42.8	38.1	19	35	6	1" - 8 UN	19	40	5/16" - 18 UNC	12	2 1/4" - 14 UN	27	4.4	HRC106
57	42.8	38.1	19	35	6	1" - 8 UN	19	40	5/16" - 18 UNC	12	2 1/4" - 14 UN	27	5.4	HRC108
57	42.8	38.1	19	35	6	1" - 8 UN	19	40	5/16" - 18 UNC	12	2 1/4" - 14 UN	27	6.4	HRC1010
57	42.8	38.1	19	35	6	1" - 8 UN	19	40	5/16" - 18 UNC	12	2 1/4" - 14 UN	27	6.8	HRC1012
57	42.8	38.1	19	35	6	1" - 8 UN	19	40	5/16" - 18 UNC	12	2 1/4" - 14 UN	27	8.2	HRC1014
70	50.8	41.3	19	38	9	1" - 8 UN	25	48	3/8" - 16 UNC	12	2 3/4" - 16 UN	30	3.3	HRC151
70	50.8	41.3	19	38	9	1" - 8 UN	25	48	3/8" - 16 UNC	12	2 3/4" - 16 UN	30	4.1	HRC152
70	50.8	41.3	19	38	9	1" - 8 UN	25	48	3/8" - 16 UNC	12	2 3/4" - 16 UN	30	5	HRC154
70	50.8	41.3	25	38	9	1" - 8 UN	25	48	3/8" - 16 UNC	12	2 3/4" - 16 UN	30	6.8	HRC156
70	50.8	41.3	25	38	9	1" - 8 UN	25	48	3/8" - 16 UNC	12	2 3/4" - 16 UN	30	8.2	HRC158
70	50.8	41.3	25	38	9	1" - 8 UN	25	48	3/8" - 16 UNC	12	2 3/4" - 16 UN	30	9.5	HRC1510
70	50.8	41.3	25	38	9	1" - 8 UN	25	48	3/8" - 16 UNC	12	2 3/4" - 16 UN	30	10.9	HRC1512
70	50.8	41.3	25	38	9	1" - 8 UN	25	48	3/8" - 16 UNC	12	2 3/4" - 16 UN	30	11.8	HRC1514
86	65.1	57.2	25	51	10	1 1/2" - 16 UN	25	59	1/2" - 13 UNC	19	3 5/16" - 12 UN	49	5.9	HRC251
86	65.1	57.2	25	51	10	1 1/2" - 16 UN	25	59	1/2" - 13 UNC	19	3 5/16" - 12 UN	49	6.4	HRC252
86	65.1	57.2	25	51	10	1 1/2" - 16 UN	25	59	1/2" - 13 UNC	19	3 5/16" - 12 UN	49	8.2	HRC254
86	65.1	57.2	25	51	10	1 1/2" - 16 UN	25	59	1/2" - 13 UNC	19	3 5/16" - 12 UN	49	10	HRC256
86	65.1	57.2	25	51	10	1 1/2" - 16 UN	25	59	1/2" - 13 UNC	19	3 5/16" - 12 UN	49	12.2	HRC258
86	65.1	57.2	25	51	10	1 1/2" - 16 UN	25	59	1/2" - 13 UNC	19	3 5/16" - 12 UN	49	14.1	HRC2510
86	65.1	57.2	25	51	10	1 1/2" - 16 UN	25	59	1/2" - 13 UNC	19	3 5/16" - 12 UN	49	16.3	HRC2512
86	65.1	57.2	25	51	10	1 1/2" - 16 UN	25	59	1/2" - 13 UNC	19	3 5/16" - 12 UN	49	17.7	HRC2514
102	73	57.2	29	51	10	1 1/2" - 16 UN	25	59	1/2" - 13 UNC	16	3 5/16" - 12 UN	49	18.1	HRC308
127	95.2	79.4	33	71	2	—	—	95	1/2" - 13 UNC	19	5" - 12 UN	55	15	HRC502
127	95.2	79.4	33	71	2	—	—	95	1/2" - 13 UNC	19	5" - 12 UN	55	19.1	HRC504
127	95.2	79.4	35	71	2	—	—	95	1/2" - 13 UNC	19	5" - 12 UN	55	23.1	HRC506
127	95.2	79.4	35	71	2	—	—	95	1/2" - 13 UNC	19	5" - 12 UN	55	31.8	HRC5010
127	95.2	79.4	35	71	2	—	—	95	1/2" - 13 UNC	19	5" - 12 UN	55	37.6	HRC5013
146	114.3	95.3	30	71	2	—	—	114	5/8" - 13 UNC	16	5 3/4" - 12 UN	44	29.5	HRC756
146	114.3	95.3	30	71	2	—	—	114	5/8" - 13 UNC	16	5 3/4" - 12 UN	44	59	HRC7513
178	130.2	104.8	41	71	2	—	—	140	3/4" - 10 UNC	25	6 7/8" - 12 UN	44	36.7	HRC1002
178	130.2	104.8	41	71	2	—	—	140	3/4" - 10 UNC	25	6 7/8" - 12 UN	44	59	HRC1006
178	130.2	104.8	41	71	2	—	—	140	3/4" - 10 UNC	25	6 7/8" - 12 UN	44	72.6	HRC10010