

## ▼ HC3 Portable Electric Hydraulic Pumps



### HC3 portable electric pumps

Maximum output pressure: 70MPa

Motor Size : 0.375KW

Low pressure flow : 3.5L/Min

High pressure flow : 0.35L/Min

Reservoirs capacity : 5L

- Gear pump plus 3 pairs radial piston pump structure, high efficiency, low noise, strong self-priming ability Brushless motor maintenance free
- Equipped with 3-meter wire control handle, pump button switch, motor overload protector.
- Built-in safety valve, external adjustable relief valve The fuel tank is equipped with fuel port, hand twist exhaust port, Sight Glass, oil drain port, handle and non-slip footing.

## ▼ HC3 Type Specification Sheet:

Model number	Voltage	Low pressure flow	High pressure flow	Reservoirs Capacity	Control valve function	Number of Oil Drains	Weight without oil
HC3005MV32	230VAC	3.5L/Min	0.35L/Min	5L	Manual unloading valve	1	19KG
HC3005MV43	230VAC	3.5L/Min	0.35L/Min	5L	M type manual reversing valve	2	19KG
HC3005EVC32R	230VAC	3.5L/Min	0.35L/Min	5L	Pressure, pressure holding, unloading	1	19KG
HC3005EVO32R	230VAC	3.5L/Min	0.35L/Min	5L	Pressure and unload	1	19KG
HC3005EVL43	230VAC	3.5L/Min	0.35L/Min	5L	Solenoid directional valve with liquid Pressure lock	2	21KG
HC3005EVB43	230VAC	3.5L/Min	0.35L/Min	5L	Solenoid directional valve with load balancing valve	2	21KG

Note: If the product needs 115VAC/60HZ operating voltage, please add -115/60HZ after it. For example, the HE3002MV32R-115/60HZ.

▼ HC3MV32 Product Illustration:

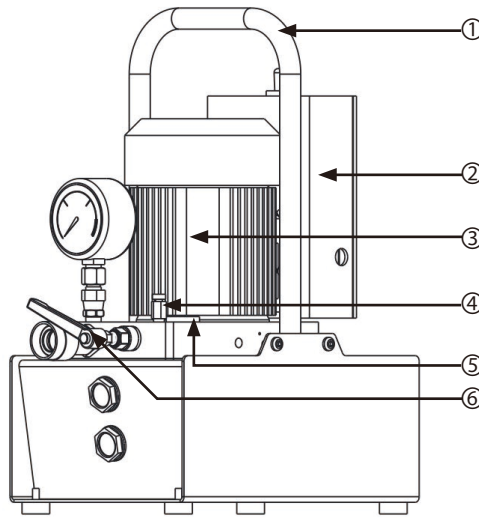
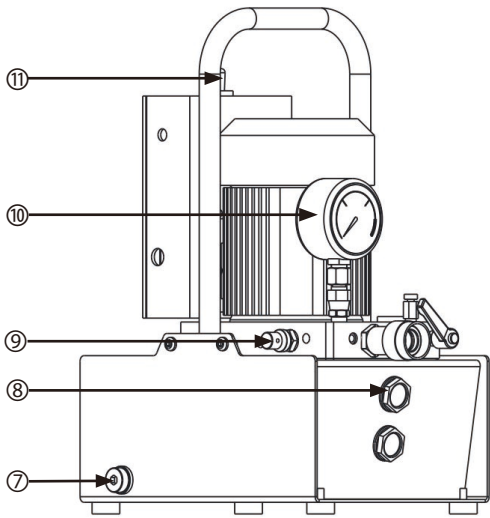

NO	Name
1	Lifting handle
2	Electric box
3	Motor
4	Exhaust port
5	Oil fill port
6	Release valve
7	Oil drain
8	Sight glass
9	Relief valve
10	Gauge
11	Twist switch

▼ HC3MV43 Product Illustration:

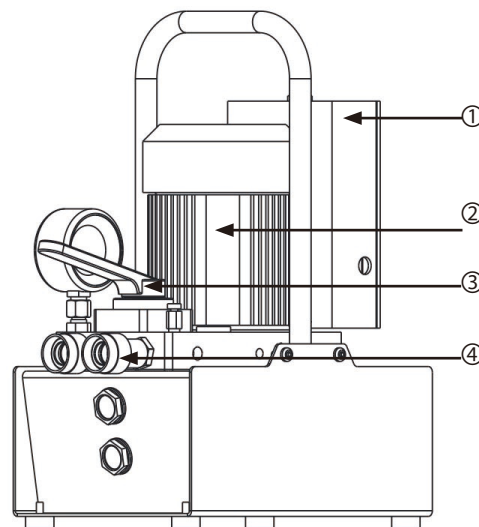
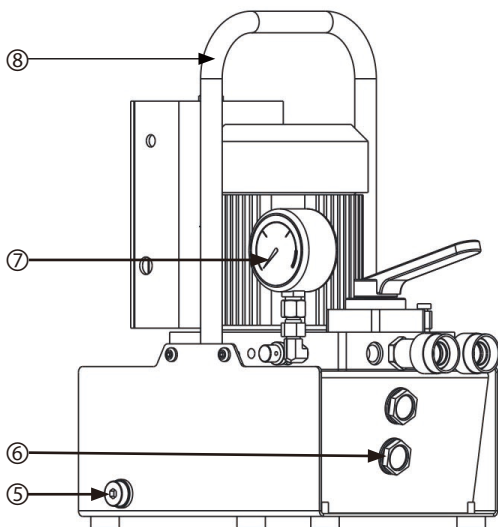

NO	Name
1	Electric box
2	Motor
3	Manual directional valve
4	Couplers
5	Oil drain
6	Sight glass
7	Gauge
8	Lifting handle

▼ HC3EV Product Illustration:

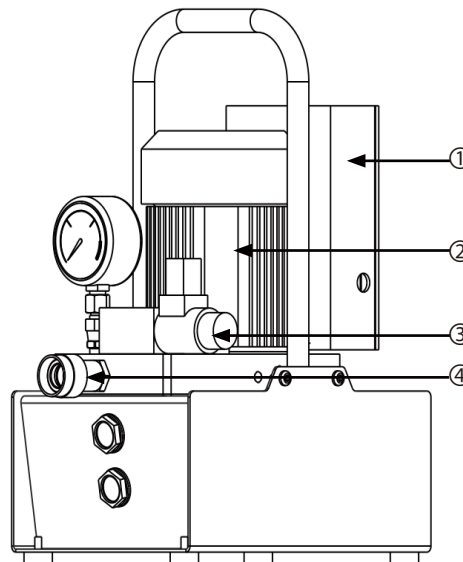
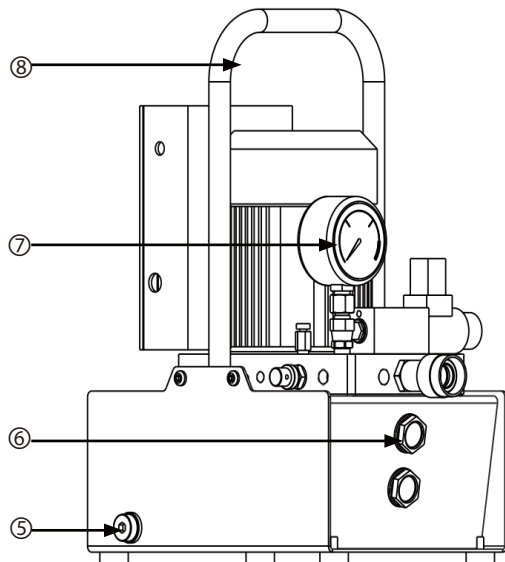

NO	Name
1	Electric Box
2	Motor
3	Solenoid ball valve
4	Couplers
5	Oil drain
6	Sight glass
7	Gauge
8	Lifting handle

# Hydraulic Oil Cylinder Pumps (70MPa)

## ▼ HC3 Outline Dimensional Drawing:

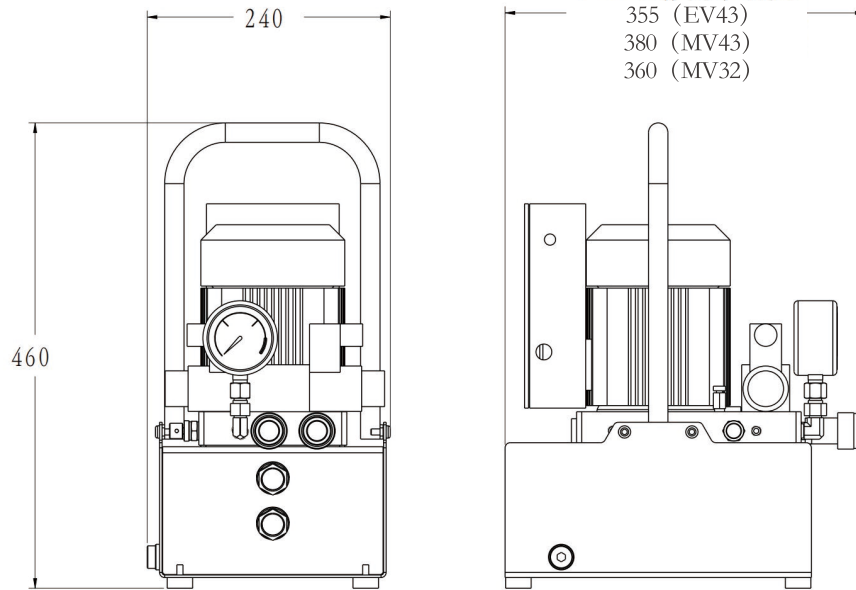

## ▼ HC3 Hydraulic Schematic Diagram:

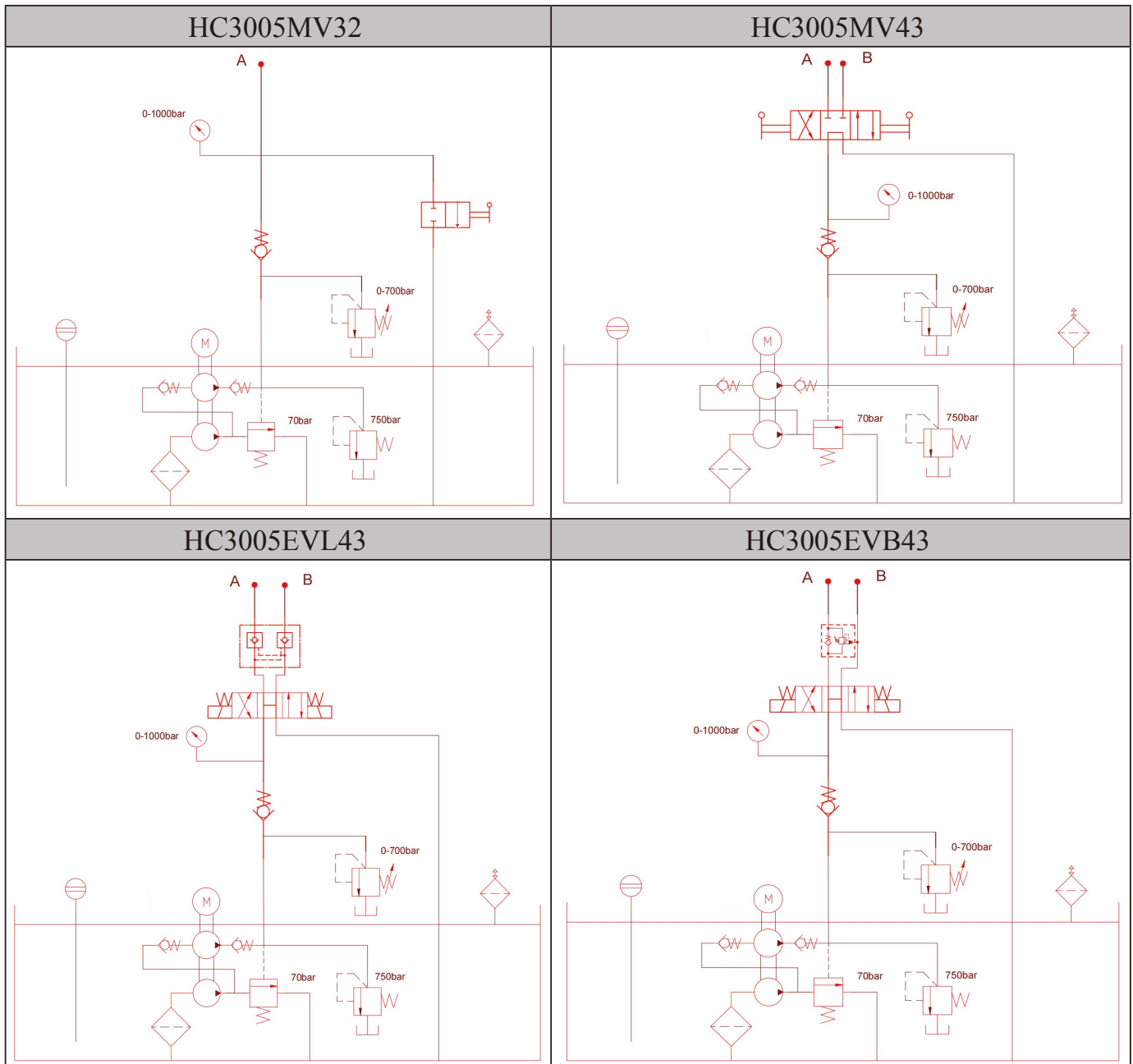

▼ HC3 Flow-Pressure Curve:

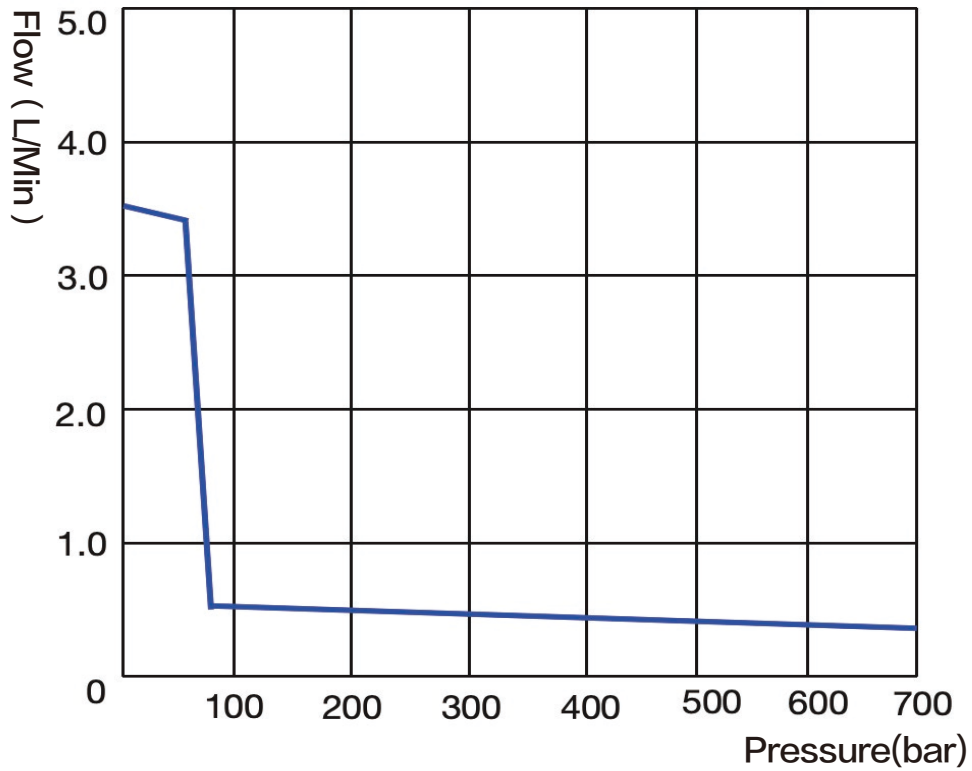

▼ Typical Model Diagram:

HC3005MV32R	HC3005MV43R	HC3005EVB43R	HC3005EVL43R
HC3005EVO32R	HC3005EVC32R		